



# **Rainbow4(s) IP Phone User Manual**

Version: 1.0

2014-09-04

# Content

<b>Contact ATCOM .....</b>	<b>5</b>
<b>1、 Overview of Rainbow4(s).....</b>	<b>6</b>
1.1、 Interface .....	7
1.2、 Hardware.....	7
1.3、 Software.....	7
1.4、 Network .....	8
1.5、 Management and Maintenance.....	8
1.6、 Protocol.....	8
1.7、 Compliant and Certified Standard.....	9
1.8、 Packing list .....	9
1.9、 Installation.....	10
<b>2、 Call Function .....</b>	<b>12</b>
2.1、 Answer the calls.....	12
Make Calls.....	13
2.3、 Pre-dial.....	15
2.4、 Multiple line dial-up .....	15
2.5、 Call Hold .....	16
2.6、 Call Transfer.....	16
2.7、 Mute calls .....	17
2.8、 3-Way Conference.....	17
2.9、 Hang up the phone.....	18
2.10、 Voicemail .....	19
<b>3、 Keypad and GUI .....</b>	<b>19</b>
3.1、 Keypad .....	19
3.2、 Starting .....	21
3.3、 Standby.....	22
3.4、 Configuration.....	24
3.4.1、 Status info .....	25
Basic Status .....	25
Details Status .....	25
Check the Status info via Web .....	26
3.4.2、 Call Features .....	26
Call Forward .....	27
Call Waiting.....	30
Auto Answer.....	31
Programmable Keys .....	32
Key as Send .....	40
Hotline .....	40
Anonymous Call.....	41
3.4.3、 Directory .....	42

Local phonebook .....	43
Blacklist .....	48
<b>3.4.4、History .....</b>	<b>48</b>
Make calls from history .....	48
Delete one item from history .....	49
Check the details of history .....	49
Add to Contact.....	50
Add to Blacklist.....	51
Delete all History's records .....	51
<b>3.4.5、Message .....</b>	<b>51</b>
Set Voice Mail .....	51
Check the voicemail .....	52
<b>3.4.6、Settings.....</b>	<b>53</b>
Basic Settings.....	53
Advanced Settings .....	61
<b>3.4.7、Display .....</b>	<b>69</b>
Slave Contrast.....	69
Backlight.....	70
<b>3.4.8、Application .....</b>	<b>71</b>
<b>4、Advanced Feature .....</b>	<b>72</b>
4.1、Codecs .....	72
4.2、Capture and Upgrading .....	73
4.3、Auto Upgrade .....	74
4.4、Export & Import configuration file.....	75
4.4.1、Export configuration file .....	76
4.4.2、Import configuration file.....	77
4.5、Export System log .....	77
4.6、Dial plan .....	78
4.6.1、Replace Rule .....	78
4.6.2、Dial-now .....	79
4.6.3、Area Code.....	81
4.6.4、Block Out.....	82
<b>5、FAQ .....</b>	<b>83</b>
5.1、How to reset to factory .....	83
5.2、Upgrade the firmware on post mode .....	84
5.3、How to make IP Peer to Peer call.....	84
<b>6、Trouble shooting .....</b>	<b>85</b>
6.1、The phone is failed to register to SIP server.....	85
6.2、The phone is failed to gain IP address .....	85
6.3、Only one party can hear from another on calling .....	85
<b>7、Abbreviation .....</b>	<b>86</b>



## Contact ATCOM

### Overview of ATCOM

ATCOM is the leading VoIP hardware manufacturer in global market. We have been keeping innovating with customer's needs oriented , working with partners to establish a total solution for SMB VoIP with IP phone , IP PBX and Asterisk cards.

With over 10 years' experience of R&D , manufacturing and service in network and VoIP filed; mission of creating the biggest value for IP terminals , we commit ourselves in supplying the competitive IP phone and other terminals for IP PBX , softswitch , IMS , NGN providers and carriers; supplying the competitive total VoIP solution for SMB market. We keep improving the customer's experience and creating the bigger value with our reliable products. Until now, our VoIP products have been available in 100+ countries and used by millions of end users.

### Contact Sales

Address	Area C, A2F , Block 3 ,Huangguan Technology Park , #21 Tairan 9th Rd, Chegongmiao , Futian District , Shenzhen China
Tel	+ (86) 755-83018618-8806
Fax	+ (86) 755-83018319
E-mail	<a href="mailto:sales@atcomemail.com">sales@atcomemail.com</a>

### Contact Technical Support

Tel	+ (86) 755-83018618-8008
E-mail	<a href="mailto:Support@atcomemail.com">Support@atcomemail.com</a>

**Website Address:** <http://www.atcom.cn/>

**Download Center:** <http://www.atcom.cn/download.html>



<b>LAN Port</b>	RJ45
<b>PC Port</b>	RJ45
<b>EXPAN Port</b>	RJ45
<b>Headset Jack</b>	RJ9
<b>Handset Jack</b>	RJ9

## 1.2、Hardware

<b>LCD</b>	<b>480x272 4.3" TFT</b>
<b>FLASH</b>	64M
<b>RAM</b>	64M
<b>CPU</b>	Rainbow4 262MHz Dual-Core Rainbow4s 393MHz Dual-Core
<b>LED Indicator</b>	1 Status Light , 4 line indicators, 8 BLF indicators, 1 voicemail indicator, 1 headset indicator, 1 mute indicator
<b>Rainbow ET Expansion Module</b>	16 programmable keys on each Rainbow ET.

## 1.3、Software

- Sip 2.0 (RFC3261) and other related SIP RFCs
- 6 SIP lines registration
- STUN
- Jitter Buffer, VAD,CNG
- G.711A/u, G722, G.723, G.726-16, G.726-24, G.726-32, G.726-40, G.729, Lin16-16, iLBC
- Echo Cancellation
- SIP Domain name, Authentication and Backup SIP Server
- DTMF(Inband, RFC2833, SIP INFO)
- Call transfer, Call forward, 3-way conference, Call hold, Call back
- DND(Do Not Disturb), Auto answer, Blacklists, Block Call-ID, Block Anonymous call, Dial plan, IP call
- Phone book with 200 records, 200 answered calls, 200 missed calls, 200 dialed calls
- Auto update via HTTP, FTP, TFTP, PNP
- Syslog
- SNTP,NTP
- Customized Ringtone
- Daylight Saving time
- VLAN, VPN

- WEB access with different login level
- Multi-language: English, Chinese, Farsi, French, German, Hebrew, Italian, Portuguese, Russian, Spanish, Turkish

## **1.4、Network**

- LAN/PC: Support Bridge mode
- Support VLAN
- Support L2TP VPN
- Support DHCP、STATIC、PPPoE
- Primary/Secondary DNS Server
- Support QoS
- Web access via HTTP & HTTPS

## **1.5、Management and Maintenance**

- Support safe mode and firmware updating under safe mode
- Support different level user management
- Configuration via web , keyboard
- Support multi-language
- Firmware and configuration file auto provision
- Support system log

## **1.6、Protocol**

- IEEE 802.3 /802.3 u 10 Base T / 100Base TX
- PPPoE: PPP over Ethernet
- DHCP: Dynamic Host Configuration Protocol
- SIP RFC3261, RFC3262, RFC3263, RFC3264, RFC3265, RFC2543, RFC3489, RFC3842, RFC3515, RFC2976, RFC3428, RFC2327, RFC2782, RFC1889
- TCP/IP: Transfer Control Protocol/Internet Protocol
- RTP: Real-time Transport Protocol
- RTCP:RTP Control Protocol
- DNS: Domain Name Server
- TFTP: Trivial File Transfer Protocol
- HTTP:Hypertext Transfer Protocol
- FTP:File Transfer Protocol



## 1.7. Compliant and Certified Standard

- CE: AGC01180140201E2, AGC01180140202E2
- Comply with ROHS in EU
- Comply with ROHS in China



- Operation temperature: lower than 60° C
- Storage temperature: lower than 60° C
- Humidity: 10 to 90% no dew

## 1.8. Packing list

Model	Rainbow4(s)
<b>Telephone</b>	1 Unit
<b>Handset</b>	1 Unit
<b>Handset cable</b>	1 Unit
Stand bracket	1 Unit
<b>Power adapter</b>	Optional
<b>Network Cable</b>	1 unit, 1.5 meters
<b>CD (User manual)</b>	1 Unit
<b>Rainbow ET</b>	Optional
<b>Headset</b>	Optional

## 1.9. Installation

Rainbow4(s) is able to be connected with network via LAN port. Under the Bridge mode, other devices (Laptop, IP phone) is able to access network via the PC port of Rainbow 4(S).

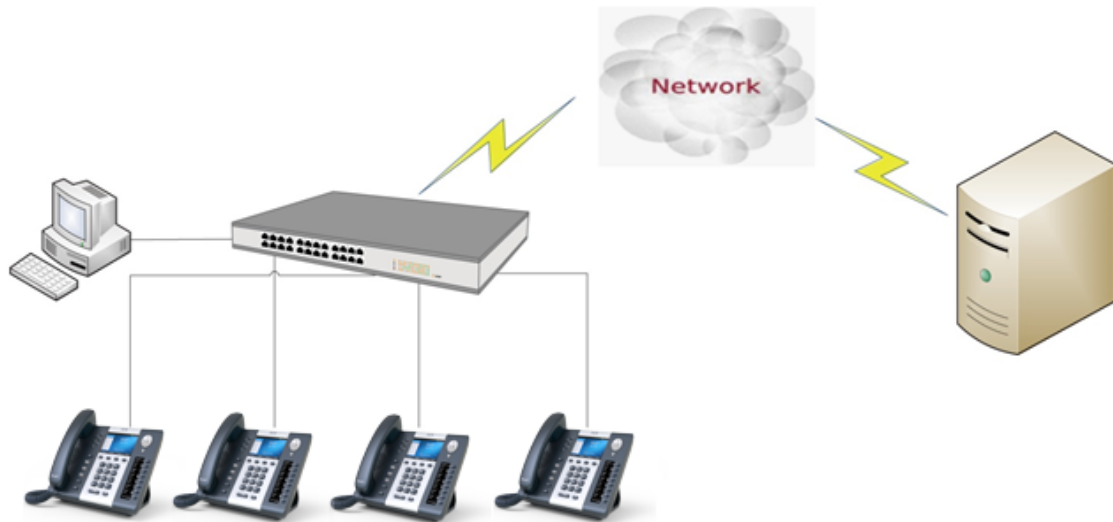

## 1、 Stand bracket installation instruction

A. Put the bottom side of the IP phone upside and press one-side joints of stand bracket into the slot, please refer the picture as below:

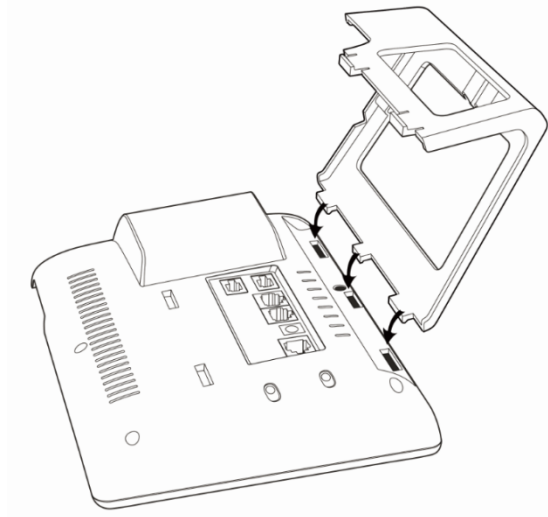

B. Press the other side joints into the slot according to the direction of the arrow:

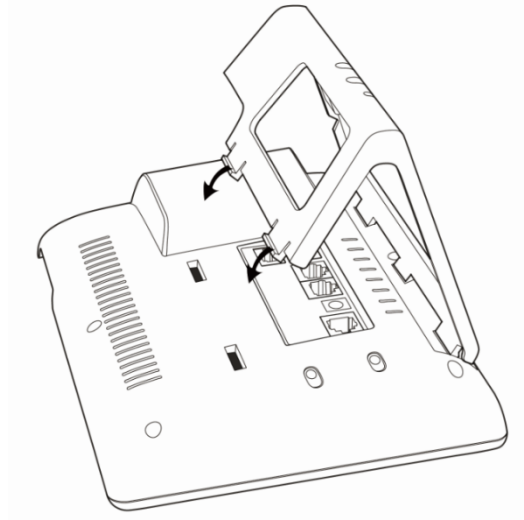

C. It is the right picture after fixing the stand bracket below:

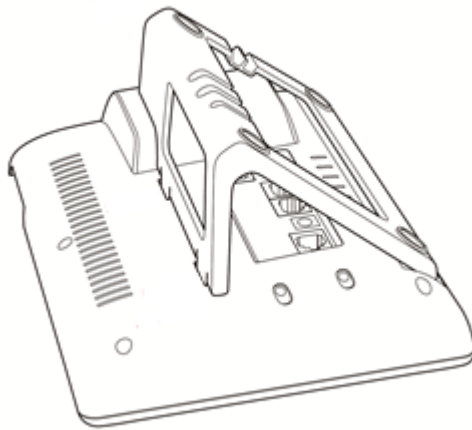

D. Disassemble the stand bracket:

Push the spring joint of stand and pull the stand according to the direction of the arrow. When the joints are pulled out of the slot, you can take off the stand bracket

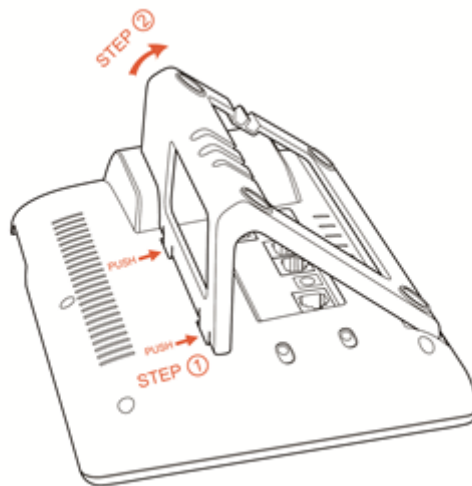

## 2、Wiring instruction

Plug in the power adapter, cable and handset or headset to the corresponding ports as below picture and press them to the slots on the stand bracket.

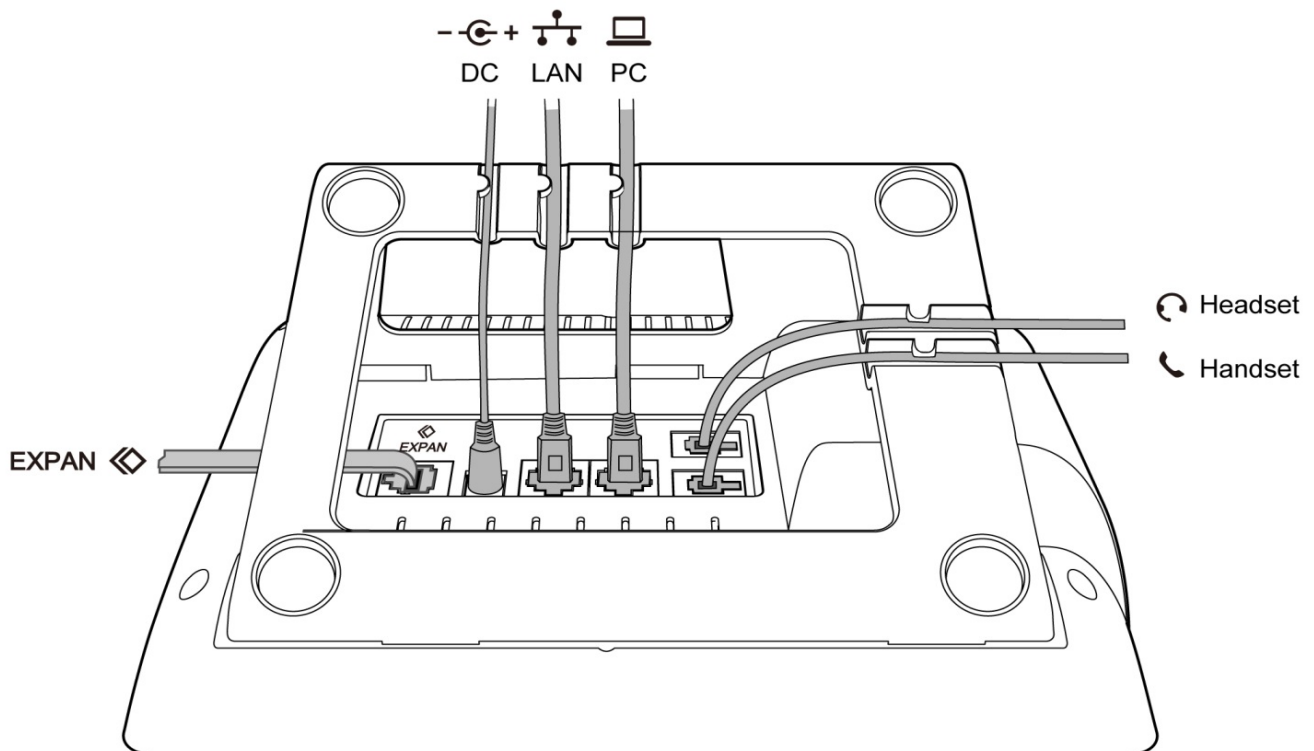

## 2、Call Function

## 2.1、 Answer the calls



When there is an incoming call, phone will remind user with ringing. There are 3 ways to answer the call:

### A. Answer by handset



Pick up the handset and talk with the caller. If you want to hang up, just put back the handset. When you are talking with the handset and want to switch to speaker

or headset mode, please press  key or  key, and then put down the handset.

### B. Answer by speaker

Press  key and talk with callers by built-in Micro-phone and Speaker. If you want to hang up, please press  key again. Switch calling or talking into handset mode by lifting the handset under speaker mode. Press  key will switch calling or talking into headset mode.

### C. Answer by headset

Keep your microphone connected with the RJ9 headset jack, when there is an incoming call, press  and talk with the caller. If you want to hang up, please press  again. Pressing  can change calling or talking into speaker mode, and lifting the handset switches to handset mode.

## Make Calls

### A. Use the handset

Pickup the handset, the LCD will show the current lines (user is able to switch from line1 to line6 by pressing the line key beside the LCD). Press soft key "**Send**" to dial the number. When you hear the tones of "du~~du~~" and the phone number your dialed is being displayed on the LCD, the phone at the side of being called should be ringing. If the called party answers this calling, the call is established and the calling timer is started immediately.



### B. Use the speaker

Press  key, the LCD will show the current lines (user is able to switch from line1 to line6 by pressing the line key beside the LCD). Input the phone number and press soft key "**Send**" to dial the number. When caller hear the tones of "du~~du~~" and the phone number your dialed is being displayed on the LCD, the phone at the side of being called should be ringing. If the called party answers this calling, the call is established and the calling timer is started immediately.



#### C. Use the headset

Press  Key, the LCD will show the current lines (user is able to switch from line1 to line6 by pressing the line key beside the LCD). Input the phone number and press soft key "**Send**" to dial the number. When caller hear the tones of "du~~du~~" and the phone number your dialed is being displayed on the LCD, the phone at the side of being called should be ringing. If the called party answers this calling, the call is established and the calling timer is started immediately.

#### D. Dial from phone book

1. Press  key to enter the menu and choose "**Directory**" option. Press "**Enter**" soft key and then find the contact person by navigation keys. When the certain contact person is highlighted, press "**Dial**" or just pick up the handset to call this number.
2. Pick up the handset, press "**Directory**" soft key, then find the contact person and press "**Dial**" soft key.
3. Pick up the handset, press  and enter "**Directory**", then find the contact person and press "**Dial**" soft key.

#### E. Dial from call history



1. Press  key to enter the menu and choose "**History**" option, then select one of call history entry, and press "**Dial**" soft key or pickup the handset to call this number.
2. Pickup the handset, press "**History**" soft key, then select one of call history entry, and press "**Dial**" soft key to call this number.
3. Pickup the handset, press  and enter "**Call History**", then select one of call history entry, and press "**Dial**" soft key to call this number.

## 2.3、Pre-dial

It's a method to dial a phone number immediacy at standby mode.

The method is as below:

A. Dial-up the phone number at standby mode



B. Press soft key "**Dial**" or Pick up the handset or Press  or  to send out the number.

## 2.4. Multiple line dial-up

Rainbow4(s) supports 6 SIP lines. That means user can register 6 different sip accounts simultaneity. User is able to choose line1, line2, line 3 , line 4, line 5 or line 6 by pressing corresponding line key. Line 1 or the 1<sup>st</sup> Line registered successfully under idle is the priority to pick up the calls.



Rainbow4(s) maximum supports 24 concurrent calls, that means 24 calls can be setup on each of single line, but the total number of concurrent calls on all lines can not more than 24. When there is an incoming call to another line, LCD will show the incoming phone number and line LED will be blinking in green. User is able to press the corresponding line key or press soft key "**Hold**" the current line on which you're talking then press "**Answer**" to receive the incoming call from another line.

Pick up a new incoming call while on calling: When a new incoming call happened

on the being occupied line, press the key  or  to check details of the new incoming call, and press the soft key "**Answer**" on GUI to pick up the new call. The current calling will be hold after the new call picked up. When a new incoming call happened on another idle line, the source phone number of new incoming call will be displayed on the Screen and the LED of corresponding line key will be fast blinking (Green), Press the corresponding line key to pick up the new call, Or Press the soft key "**Hold**" to hold the current call and then press "**Answer**" key to pick up the new call.

Make a new call while on calling: To make a new call on a being occupied line, Press the key "**Hold**", then input the destination phone number and press the key "**Dial**", or Press the soft key "New", then input the destination phone number and press the key "**Dial**". To make a new call on an idle line, press the corresponding line key, input the destination phone number and press the key "**Dial**".

## 2.5. Call Hold

The current calling will be hold by pressing soft key "**Hold**" or , and the held call will be resumed after pressing soft key "**Resume**" or  or the

corresponding line key. Even on 3-way conference calling, the conference will be held after pressing "**Hold**" key, and be resumed to 3-way conference after pressing "**Hold**" Key again. Remember the conversation is still on hold without being ended even if hung up under the status of hold.

## 2.6、 Call Transfer

### 1. Attended call transfer

The attended transfer allows user to call a third-party before transferring the calling.

While calling, press the "**Transfer**" soft key to hold the current call and dial the target number you want to transfer to on the activated line and press "**Send**" soft key to call that number. After the target party answers the call, press "**Transfer**" soft key again to complete the transfer.

If the target number has been setup in the current BLF list, and you have already finished the necessary setup on Webpage of Rainbow4(s), there is an easier way to complete the attend transfer. While calling, press the corresponding BLF key of the target number and then press the "**Transfer**" soft key, the attend transfer will be achieved.

Setup BLF list with attend transfer functions on Webpage:

**"Phone" → "Features" → "Transfer Settings" → "Transfer Mode via DSS Key (Attend Transfer)"**

### 2. Blind call transfer

The blind transfer allows user to transfer a call without speaking to the third party. On the user side, the call will be ended as soon as the target phone number is dialed.

Operating steps: Press "More" soft key to get more option, then press "Bxfer" soft key, input the transfer target number and press "Send" soft key.



If the target number has been setup in the current BLF list, and you have already finished the necessary setup on Webpage of Rainbow4(s), there is an easier way to complete the Blind transfer. While calling, press the corresponding BLF key of the target number, the blind transfer will be achieved.

Setup BLF list with blind transfer functions on Webpage:

**"Phone" → "Features" → "Transfer Settings" → "Transfer Mode via DSS Key (Blind Transfer)"**

## 2.7、 Mute calls



The input audio will be not transmitted to peer phone after pressing  key, and the phone will be muted even switched among different modes of speaker, handset and headset. To un-mute, just press  key again.

## 2.8、3-Way Conference

1. While on calling, press the soft key "**Conf**", input the 3<sup>rd</sup> party's phone number and then press the softkey "**Dial**" or press the soft key "**Conf**" and press the corresponding BLF key to invite the 3<sup>rd</sup> party to join a conference call.
2. After the third party answers the call, pressing "**Conf**" key again to establish the 3-way conference
3. The initiator of 3-way conference can press the soft key "**Hold**" to hold the conversation with other two parties, and press "**Resume**" to back to 3-way conference.
4. If the initiator hangs up the call or press the soft key "**End Conf**", the conference will be ended and the calling between the other two parties will be hung up as well.
5. The initiator of 3-way conference can press the soft key "**Split**" to separate the conference call, and the calling between initiator and the other two parties are still active but under the status of Call hold.
6. After split the 3-way conference, press the soft key "**More**" and then press the softkey "**Join**" to resume the 3-way conference or press the softkey "**Conf**" to setup a new 3-way conference call.

## 2.9、Hang up the phone

1. Softkey hang up

While on calling, press the softkey "**End Call**" to hang up.

2. Handset hang up

Put back the handset at handset mode, the current calling will be hung up.

3. Speaker hang up

Press  key at speaker model, the current calling will be hung up.



4. Headset Hang up

Press  key at headset model, the current calling will be hung up.

5. Hang up one line call

Press the hook to hang up the current calling when 2 calls happened simultaneously.

## 2.10、Voicemail

Rainbow4(s) has a  key for entering voicemail box and indicating new voicemail. Press  key to enter the menu to configure voicemail number if you have never configured it previously. Otherwise, the voicemail number will be called after pressing it.







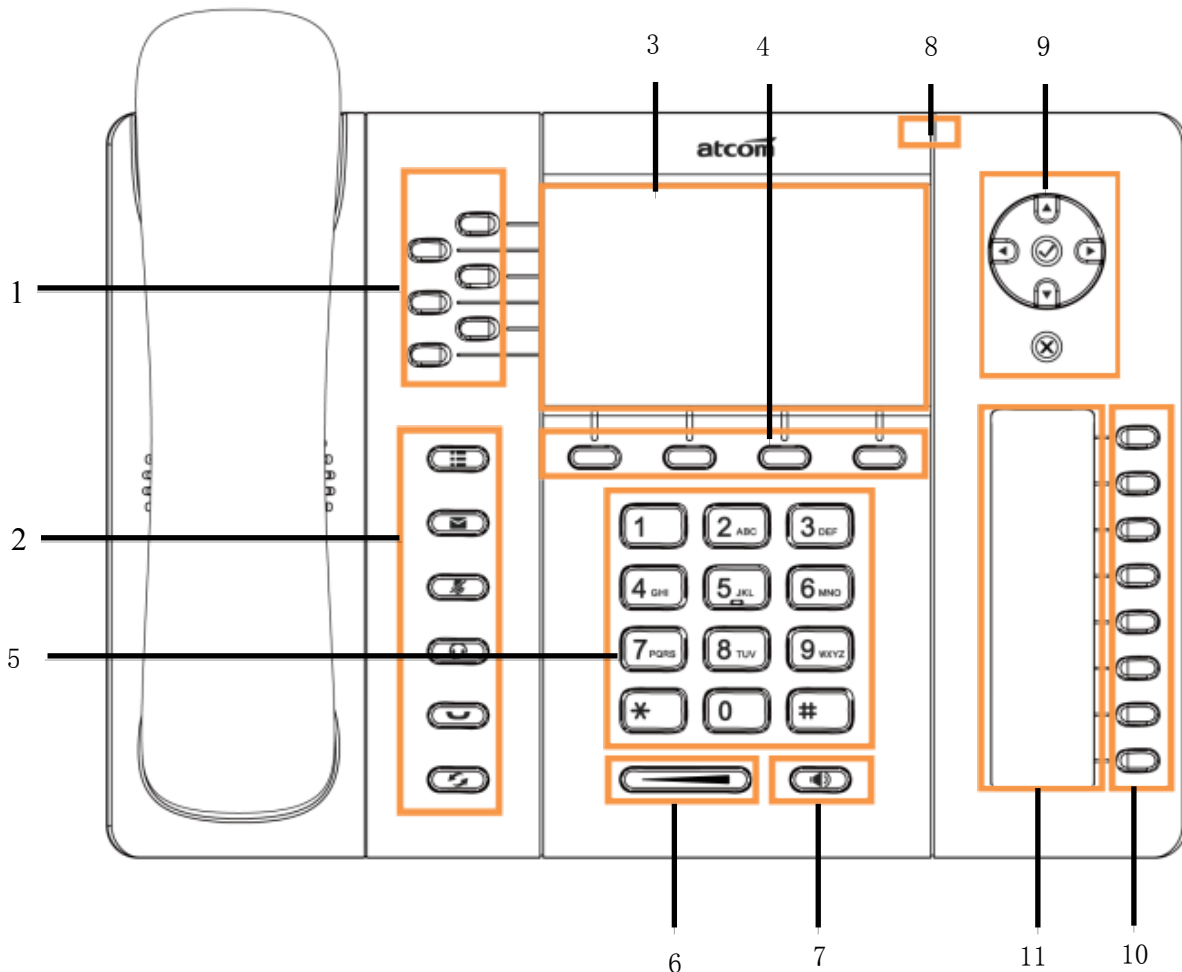



## 3、Keypad and GUI

### 3.1、Keypad

#### Description of the keys and Screen

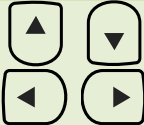

Item	Name or Icon	Description
1	Line Key and Status Indicator	<p>Programmable keys with built-in Red/Green dual-color LED lights to indicate different status of each line,</p> <ul style="list-style-type: none"> <li>● Green on always—the current line is being occupied</li> <li>● Green fast blinking—A new incoming call on the current line</li> <li>● Red on always—The remote end of SLA is busy</li> <li>● Green slow blinking—Calling on the current line has been hold by the remote end</li> <li>● Red slow blinking — Calling on the current line has been hold by local end.</li> </ul>
2		Enter/Quit Menu

		Access & Manage the Voicemail
		Mute
		Make a call or answer a call on headset
		Hold/Resume a call
		Re-dial the latest dialed phone number
<b>3</b>	Main LCD Display	Display Calling details, Message, Softkey, Time, Date and other info.
<b>4</b>	Softkey	Press to select a function which displayed at the softkey zone of screen. Display all optional functions at the last line of LCD screen.
<b>5</b>	Dial pad	Entering numbers or characters.
<b>6</b>		Adjust the volume (speaker/handset/headset/ring). Volume level will be displayed on LCD when pressing volume key.
<b>7</b>		Pick up and hung up under the speaker mode.
<b>8</b>	Status Indicator	The Status Indicator (LED) will be Red slow blinking when new incoming call or Voicemail.
<b>9</b>		Allow users to navigate (left, right, up, down). Press  can enter "Directory". Press  can enter "History".
		Confirm users' operation and show status when Rainbow2 is idle.
		Cancel users' operation.
<b>10</b>	Memory Key and Status Indicator	Aside the BLF LCD display, Programmable keys with built-in Red/Green dual-color LED lights to indicate different status: <ul style="list-style-type: none"> <li>● Off—The account is unregistered</li> <li>● Green on always—The account is idle.</li> <li>● Red on always — The account is being occupied.</li> <li>● Red fast blinking—The account is ringing.</li> </ul>
<b>11</b>	BLF LCD Display	Display the content of each programmable key.

### 3.2、Starting

All lights will be on (Red) at the moment when the phone powered on, and then light off in the following One second. And then the phone turns to standby status in about 50 seconds.





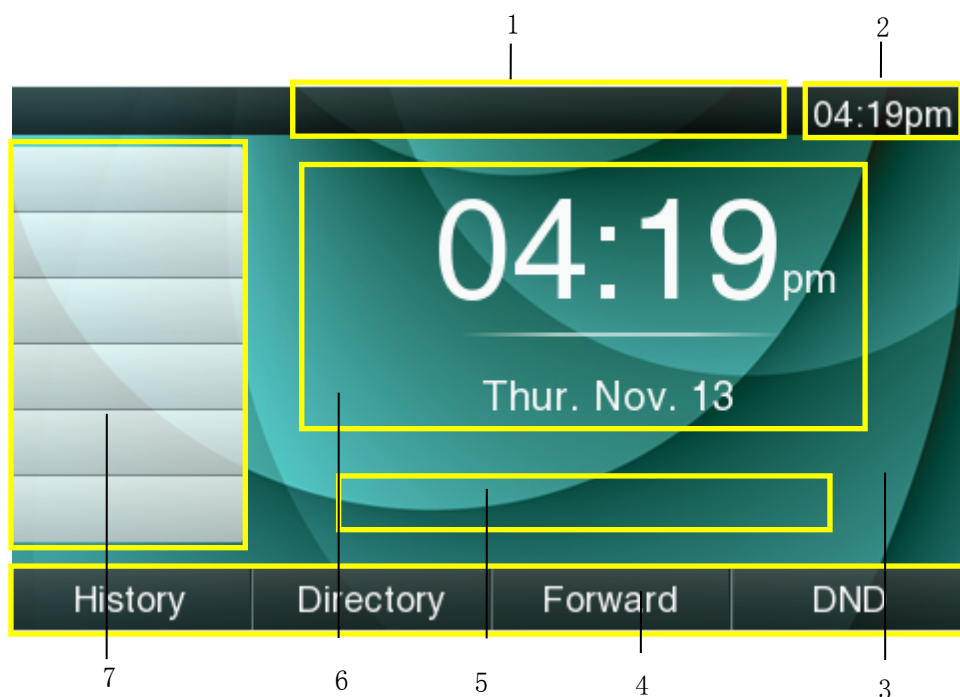















### 3.3、Standby



Area Item	Description
1	Status: to indicate the call status
2	Time
3	Background
4	Softkey: “ <b>History</b> ”, “ <b>Directory</b> ”, “ <b>Forward</b> ”, “ <b>DND</b> ”
5	Indication info: DND (on)、Missed calls, Call Forward (on) and Network Status (unavailable).

<b>6</b>	Time, Date
<b>7</b>	Programmable keys (Line Keys in default)

## Icon on Standby UI

Icon	Description
	The account is registered successfully, and displayed in the Area 7.
	The account is not registered successfully, and displayed in the Area 7.
	The line is being occupied for dialing, and displayed in the Area 7.
	The line is on calling, and displayed in the Area 7.
	New incoming call, and displayed in the Area 7.
	Call hold, and displayed in the Area 7.
	3-way conference calling, and displayed in the calling UI.
	Call being hold, and displayed in the calling UI.
	Unavailable Network, and displayed in the Area 5.
	Calling via handset, and displayed in the Area 1.
	Calling via Speaker, and displayed in the Area 1.
	Calling via headset, and displayed in the Area 1.
	WiFi Signal indicator, and displayed in the Area 1.
	Call Forward is activated, and displayed in the Area 1.
	New Voicemail, and displayed in the Area 1.
	Volume turn to be "0" , and displayed in the Area 1.
	Auto-Answer is activated, and displayed in the Area 1.
	DND is activated, and displayed in the Area 1.

### 3.4. Configuration

Press the key  to enter the Main Menu:

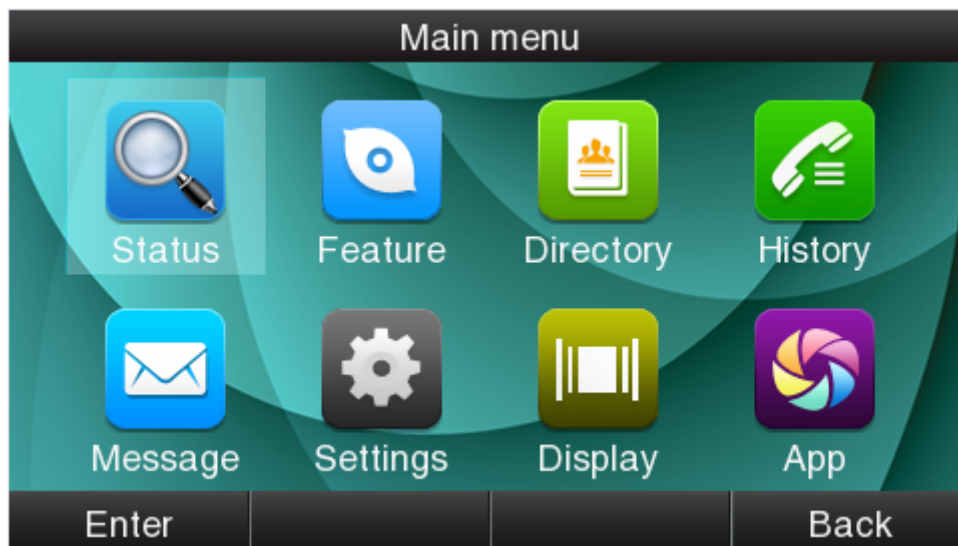

Move the cursor via navigation key and press the softkey “**Enter**” or input the corresponding Number key Select the item of Main Menu:

Number Key “ <b>1</b> ”	Enter “Status”
Number Key “ <b>1</b> ”	Enter “Feature”
Number Key “ <b>3</b> ”	Enter “Directory”
Number Key “ <b>4</b> ”	Enter “History”
Number Key “ <b>5</b> ”	Enter “Message”
Number Key “ <b>6</b> ”	Enter “Settings”
Number Key “ <b>7</b> ”	Enter “Display”
Number Key “ <b>8</b> ”	Enter “Application”

### 3.4.1、Status info



It’s able to check the status info via LCD Display or Web.

And the basic status and details status will be optional displayed on LCD display

1. Basic Status——IP address、MAC address、Firmware version。
2. Details Status——Network info、Production info and Account info in details.

#### Basic Status

You’re able to check the basic status in both ways as below:

1. Press the key  on standby.
2. Press the key  and select the “Status” of Main Menu.





3. Input the username and password, the default user and password for Administrator is (admin, admin), for general user is (user, user), and then press "**Enter**".
4. By default, the Status info will be displayed.

### 3.4.2. Call Features

In this part, we will introduce the following content:

- [Call Forward](#)
- [Call Waiting](#)
- [Auto Answer](#)
- [Programmable keys](#)
- [Key as send](#)
- [Hotline](#)
- [Anonymous Calls](#)

#### Call Forward

"Call Forward" includes "Always Forward", "Busy Forward", "No Answer Forward". "Always Forward" has the highest priority, and "Busy Forward" has the same priority as "No Answer Forward", that means once the function of "Always Forward" is activated, other call forward features will be unavailable.

Any type of Call forward feature is activated, the Icon  will be indicated on the LCD Display, and the soft key "Forward"(at the bottom line of LCD display) will turn to be "-Forward".

#### *Always Forward*

All incoming calls will be forwarded to target phone number once the "**Always Forward**" activated, setup this feature as follow:

Always Forward	
1. Always	Enable ◀ ▶
2. Forward to	6040
3. On Code	#36
4. Off Code	#366
<div style="display: flex; justify-content: space-between; width: 100%;"> <span>Save</span> <span>Switch</span> <span>Back</span> </div>	

Item	Operation	Description
<b>Always</b>	Press the key  or the soft key "Switch" to setup	Switch on or Switch off the feature. "Enable" mean this feature is enabled, "Disable" mean this feature is disabled .
<b>Forward to</b>	The Number key, "*" key, and "#" are permitted to be input.	Setup the target phone number which all incoming calls transferred to
<b>On Code</b>	The Number key, "*" key, and "#" are permitted to be input.	The feature code to enable all incoming calls forward, the phone will send the feature code directly to open all incoming calls forward
<b>Off Code</b>	The Number key, "*" key, and "#" are permitted to be input.	The feature code to disable all incoming calls forward, the phone will send the feature code directly to close all incoming calls forward

### ***Busy Forward***

It means the phone is busy once the phone is not at standby mode. Setup this feature as below:



Busy Forward	
1. Busy	Enable ◀ ▶
2. Forward to	6039
3. On Code	#37
4. Off Code	#377
<div style="display: flex; justify-content: space-around;"> <span>Save</span> <span>Switch</span> <span>Back</span> </div>	

Item	Operation	Description
<b>Busy</b>	Press the key  or softkey "Switch" to setup	Switch on or Switch off the feature. "Enable" mean this feature is enabled, "Disable" mean this feature is disabled.
<b>Forward to</b>	The Number key, "*"key, and "#"are permitted to be input.	Setup the target phone number which all incoming calls transferred to
<b>On Code</b>	The Number key, "*"key, and "#"are permitted to be input.	The feature code to enable busy calls forward, the phone will send the feature code directly to open busy call forward
<b>Off Code</b>	The Number key, "*"key, and "#"are permitted to be input.	The feature code to disable busy calls forward, the phone will send the feature code directly to close busy call forward

### *No Answer Forward*

All incoming calls will be forwarded after time out, once the feature of "No Answer Forward" is activated. Setup this feature as below,

No Answer Forward	
1. No Answer	Enable ◀ ▶
2. Forward to	6038
3. After Ring Time	5s ◀ ▶
4. On Code	#38
5. Off Code	#388
<div style="display: flex; justify-content: space-between; width: 100%;"> <span>Save</span> <span>Switch</span> <span>Back</span> </div>	

Item	Operation	Description
<b>No Answer</b>	Press the key  or softkey " <b>Switch</b> " to setup	Switch on or Switch off the feature. " <b>On</b> " mean this feature is activated, " <b>Off</b> " mean this feature is unactivated .
<b>Forward to</b>	The Number key, "*"key, and "#"are permitted to be input.	Setup the target phone number which all incoming calls transferred to
<b>After Ring Time</b>	Press the key  or softkey " <b>Switch</b> " to setup	Setup timer for no answer status. All incoming calls will be forwarded after time out once Call forward when no answer activated.
<b>On Code</b>	The Number key, "*"key, and "#"are permitted to be input.	The feature code to enable no answer call forward, the phone will send the feature code directly to open all incoming calls forward
<b>Off Code</b>	The Number key, "*"key, and "#"are permitted to be input.	The feature code to disable all incoming calls forward, the phone will send the feature code directly to close all incoming calls forward

### Setup Call Forward Via Web

Set Call Forward via web: **Phone**→**Features**→**Forward**.

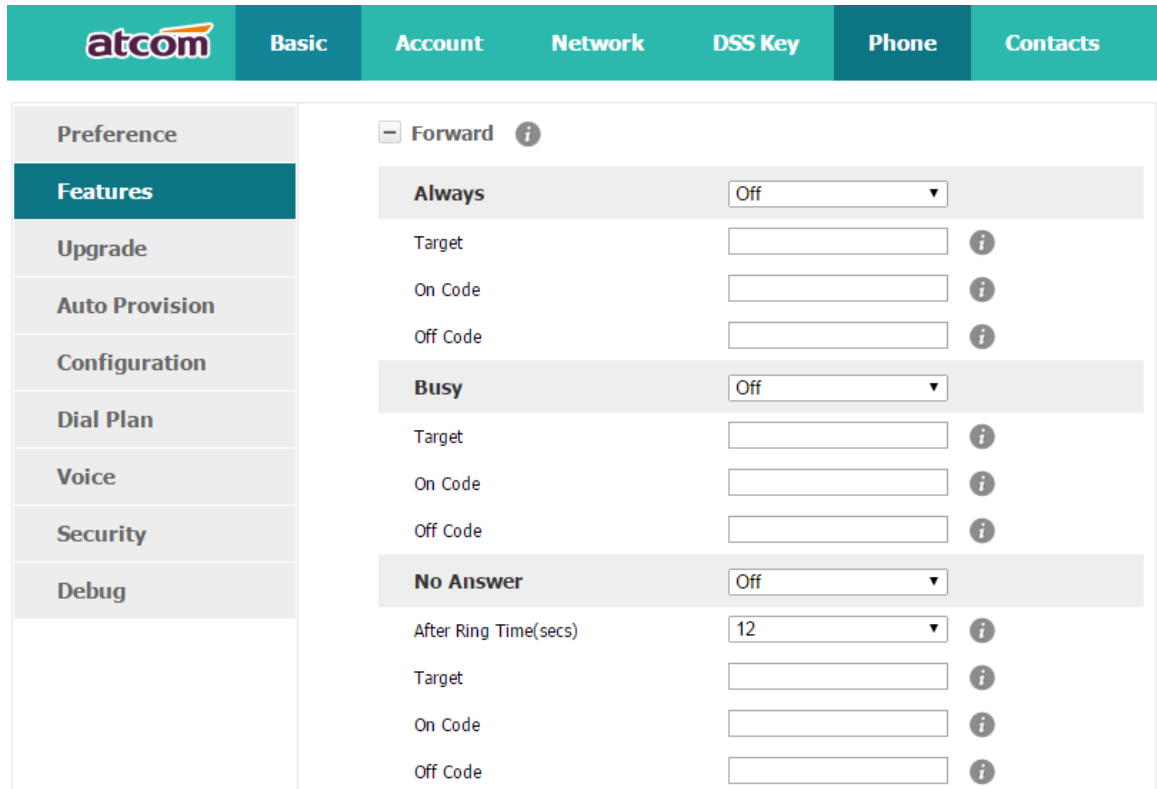

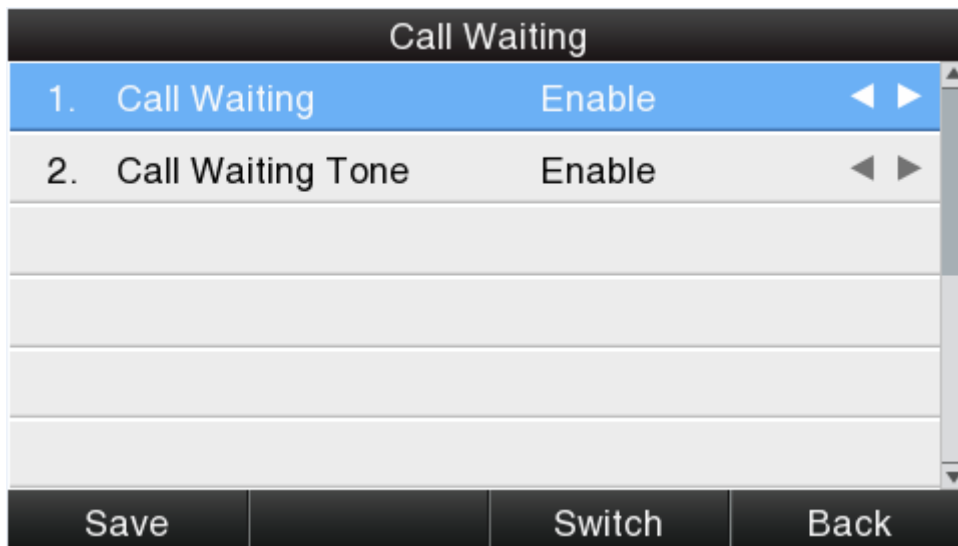

## Call Waiting

The feature of “Call Waiting” is available by default. If switch off this feature, whatever multiple SIP accounts had been registered successfully, only one single active calling is permitted (for example Dialing, Ringing, Calling, Holding).



Item	Operation	Description
<b>Call Waiting</b>	Press the key  ,  or softkey “ <b>Switch</b> ” to setup	Switch on or Switch off the feature. “ <b>Enable</b> ”mean this feature is enabled, “ <b>Disable</b> ”mean

<p><b>Call Waiting Tone</b></p>	<p>Press the key  ,  or softkey <b>“Switch”</b> to setup</p>	<p>this feature is disabled. Switch on or Switch off the prompt playing. <b>“Enable”</b>mean this feature is enabled, <b>“Disable”</b>mean this feature is disabled .</p>
---------------------------------	--	---

Setup call waiting via web: **“Phone”**→ **“Feature”**→ **“General information”**→ **“Call Waiting”**.

Setup call waiting Tone via web: **“Phone”**→ **“Feature”**→ **“Audio Settings”**→ **“Call Waiting Tone”**.

### Auto Answer

The feature of “Auto Answer” is switched off by default. All incoming calls will be answered automatically when the phone is standby once “Auto Answer” is activated. “Auto Answer”when the phone is under “on Calling” status.

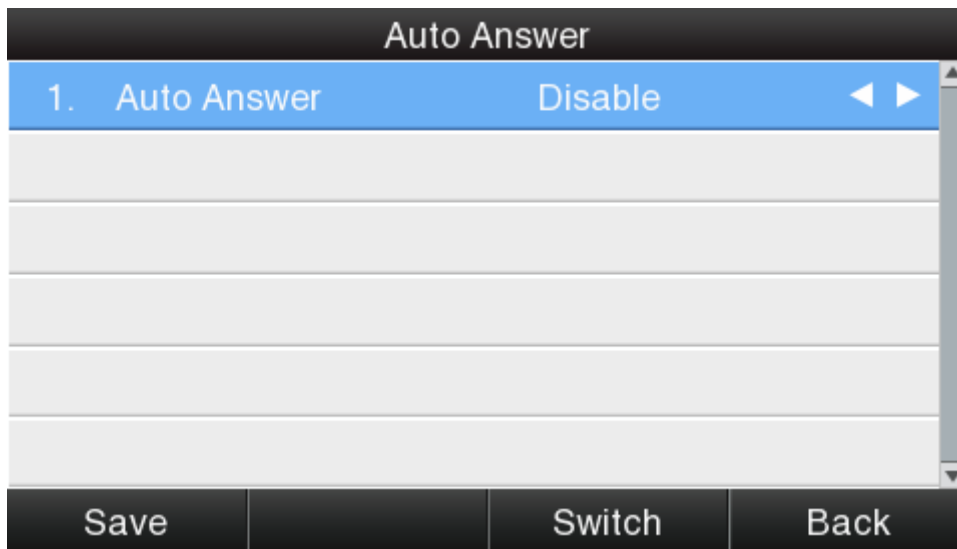

The Icon  will be indicated once “Auto Answer” is available.

Setup “Auto Answer” via Web:**“Phone”**→**“Feature”**→**“General information”**→**“Auto Answer”**

### Programmable Keys

Theprogrammable keys include Line keys, Memory keys (aside the BLF LCD Display). Programmable feature keys and Soft key on Standby UI. Press the programmable key for 2 seconds, you’re able to modify the feature of each programmable key.

All programmable keys have been classified as "N/A", "Line Key", "BLF", "Key event", "Speed dial", "Intercom"

And the "Key Event" has been classified as

"Conference", "Hold", "DND", "Redial", "Call return", "Pickup", "Call Park", "DTMF", "Directory".

Comments:

**N/A**

N/A means this key is not permitted to be set as a programmable key.

**Line key**



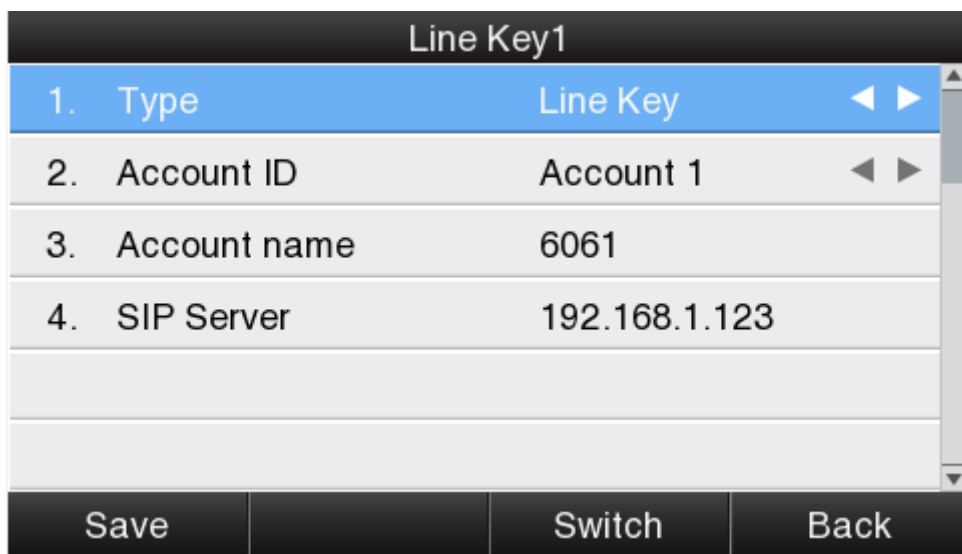

Display the account information, press it for making a call, answering incoming calls, call hold and resume.





Item	Description
<b>Account ID</b>	To display the account ID, press the soft key "Switch" or   to modify, the optional value is Account 1 to 6.
<b>Account name</b>	Display the account name of each account ID, non-modifiable.
<b>SIP Server</b>	The SIP server of each Account ID, non-modifiable. If not set any value for some account ID, the account name will be null.

**BLF**

Indicate the status of monitored account. Once set the BLF key with Pickup feature, user is able to answer the incoming call to the monitored account by pressing the corresponding BLF key. If the monitored account is idle, press the corresponding BLF key for speed dial.

Line Key1	
1. Type	BLF  
2. Account ID	Account 1  
3. Label	blf
4. Value	6070
5. Extension	*8
<div style="display: flex; justify-content: space-around;"> <span>Save</span> <span>Switch</span> <span>Back</span> </div>	

Item	Description
<b>Account ID</b>	To display the account ID, press the soft key " <b>Switch</b> " or   to modify, the optional value is Account 1 to 6.
<b>Label</b>	To identify this key on LED, for example "blf"
<b>Value</b>	The phone number will be monitored by this key. For example, if user want to monitor the phone number (6070), please set "6070" here.
<b>Extension</b>	This code must be setted for pickup, and this code provide by Server. If the code is not matched by Server, the feature of pickup will not work.

### Conference

The 3-way conference will be setup by pressing the key "Conf" while on calling. For more info, please refer to [Chapter 2.8](#).

The configuration item **Label** is a name to identify the key on LED, can be set as "conference".

### Hold

The same feature as the key . For more info, please refer to [Chapter 2.5](#).

The configuration item **Label** is a name to identify the key on LED, can be set as "hold".

### DND

Press this key will switch on or switch off the feature of "DND".

The configuration item **Label** is a name to identify the key on LED, can be set as "DND".

### Redial

The same feature as the key .



The configuration item **Label** is a name to identify the key on LED, can be set as "redial".

### Call return



Automatically dial the latest phone number in history.

The configuration item **Label** is a name to identify the key on LED, can be set as "return".

### Call Pickup

Press this key to pick up if new incoming call to the monitored phone number.

Line Key1	
1. Type	Key event ◀ ▶
2. event	Pickup ◀ ▶
3. Account ID	Account 1 ◀ ▶
4. Label	pickup
5. Value	6001
<div style="display: flex; justify-content: space-around;"> <span>Save</span> <span>Switch</span> <span>Back</span> </div>	

Item	Description
<b>Account ID</b>	To display the account ID, press the soft key "Switch" or   to modify, the optional value is Account 1 to 6.
<b>Label</b>	To identify this key on LED, for example "pickup"
<b>Value</b>	The phone number monitored for pickup

Reminding: This code must be set for pickup, and this code can be set via Web only.

Set the Pickup code as follow:



Set the pickup code for one single Account: **Account**→**Advanced**→**Select an account to be configured**→**Directed Call Pickup Code**.

Set the pickup code for all Accounts: **Phone**→**Features**→**Call Pickup**→**Direct Call Pickup**, **Direct Call Pickup Code**(**Direct Call Pickup should be set as Enable**).

### Call Park

Press this key while on calling, the phone will dial the specified phone number, user will receive a code on the phone prompt, and then press the soft key "Transfer", the current calling will be parked successfully. At this moment, user is able to continue the parked calling with any other phones which registered on the same SIP server by dialing the code which user have received.

Line Key1	
1. Type	Key event
2. event	Park
3. Account ID	Account 1
4. Label	park
5. Value	700
<div style="display: flex; justify-content: space-between; width: 100%;"> <span>Save</span> <span>Switch</span> <span>Back</span> </div>	

Item	Description
<b>Account ID</b>	To specify an account to park the call, press the soft key "Switch" or   to modify, the optional value is Account 1 to 6.
<b>Label</b>	To identify this key on LED, for example as "park".
<b>Value</b>	The code for pickup the parked call and it is provided by SIP server.

## DTMF

Press this key while on calling, the phone will send the configured "Value" automatically.

Memory Key2	
1. Type	Key event
2. event	DTMF
3. Label	dtmf
4. Value	6001#7*
<div style="display: flex; justify-content: space-between; width: 100%;"> <span>Save</span> <span>Switch</span> <span>Back</span> </div>	

Item	Description
<b>Label</b>	To identify this key on LED, for example "DTMF".
<b>Value</b>	The value sent to remote end while on calling.

## Directory



Press this key to access Directory.

The configuration item **Label** is a name to identify the key on LED, can be set as "phonebook".

### Speed Dial

Press this key while standby state, the specified target phone number will be dial from the specified account.

Memory Key2	
1. Type	Speed dial
2. Account ID	Account 1
3. Label	speeddial
4. Value	6056
Save      Switch      Back	



Item	Description
<b>Account ID</b>	To display the account ID, press the soft key " <b>Switch</b> " or   to modify, the optional value is Account 1 to 6.
<b>Label</b>	To identify this key on LED, for example "speeddial"
<b>Value</b>	The target phone number for speed dial

### Intercom

Press this key when the phone is idle, the phone will dial the specified "Value", and the remote end will answer the call automatically.

Note: This feature is supported by specified servers only.

Memory Key2	
1. Type	Intercom ◀ ▶
2. Account ID	Account 1 ◀ ▶
3. Label	intercom
4. Value	6010
<div style="display: flex; justify-content: space-around;"> <span>Save</span> <span>Switch</span> <span>Back</span> </div>	

Item	Description
<b>Account ID</b>	To display the account ID, press the soft key <b>Switch</b> or   to modify, the optional value is Account 1 to 6.
<b>Label</b>	To identify this key on LED, for example "intercom".
<b>Value</b>	The target phone number for Intercom

The programmable key configured via web included Memory Key, Line Key, Programmable Feature Key, and Feature key of expansion module.

 <span>Basic</span> <span>Account</span> <span>Network</span> <span>DSS Key</span> <span>Phone</span> <span>Contacts</span>						
<b>Memory Key</b>	Key	Type	Value	Label	Account	Extension
<b>Line Key</b>	DSS Key1	N/A			Auto	
<b>Programmable Key</b>	DSS Key2	Line			Account 1	
<b>EXT Key</b>	DSS Key3	Speed Dial	6050	speed dial	Account 1	
	DSS Key4	BLF	6049	BLF	Account 1	*8
	DSS Key5	Direct Picku	6048	call pickup	Account 1	
	DSS Key6	Call Park	700	call park	Account 1	
	DSS Key7	Intercom	6051	intercom	Account 1	
	DSS Key8	DTMF	6750#	DTMF	Auto	
	DSS Key9	Conference		conference	Auto	
	DSS Key10	Hold		hold	Auto	
	DSS Key11	DND		DND	Auto	
	DSS Key12	Redial		redial	Auto	
	DSS Key13	Directory		directory	Auto	
	DSS Key14	Call Return		call return	Auto	

## Key as Send

The key "Key as Send" has the same function as the soft key "Dial".



If switch on the feature "Rejection", all incoming anonymous calls will be blocked automatically.

Anonymous Call		
1. Accounts	Account 1	◀ ▶
2. Anonymous Call	Disable	◀ ▶
3. Call On Code		
4. Call Off Code		
5. Rejection	Disable	◀ ▶
6. Reject On Code		
Save		Switch Back

Item	Operation	Description
<b>Accounts</b>	press the soft key "Switch" or ◀, ▶ to modify,	Select the Account for anonymous call.
<b>Anonymous Call</b>	press the soft key "Switch" or ◀, ▶ to modify,	Switch on/off the feature of making anonymous calls.
<b>Call On Code</b>	The Number key, "*"key, and "#"are permitted to be input.	Set the feature code to turning on anonymous call, the phone enables anonymous call by sending the feature code to the server
<b>Call Off Code</b>	The Number key, "*"key, and "#"are permitted to be input.	Set the feature code to turning off anonymous call, the phone disables anonymous call by sending the feature code to the server
<b>Rejection</b>	press the soft key "Switch" or ◀, ▶ to modify	Switch on/off the feature of blocking anonymous calls.
<b>Reject On Code</b>	The Number key, "*"key, and "#"are permitted to be input.	Set the feature code to turning on anonymous call rejection, the phone enables anonymous call rejection by sending the feature code to the server
<b>Reject Off Code</b>	The Number key, "*"key, and "#"are permitted to be input.	Set the feature code to turning off anonymous call rejection, the phone disables anonymous call rejection by sending the feature code to the server

Set Anonymous Call via web: **Account**→**Basic**→**Select the Account**→**Anonymous Call**.

Set Anonymous Call Rejection via web: **Account**→**Basic**→**Select the Account**→**Anonymous Call Rejection**.

### 3.4.3、Directory

The content of Directory includes local phonebook and blacklist. Enter Directory as follow,

1. Press the soft key "Directory" when the phone is standby

2. Press the navigation key 

3. Press the menu key , and then select "Directory"

Configure the "Directory" via Web:

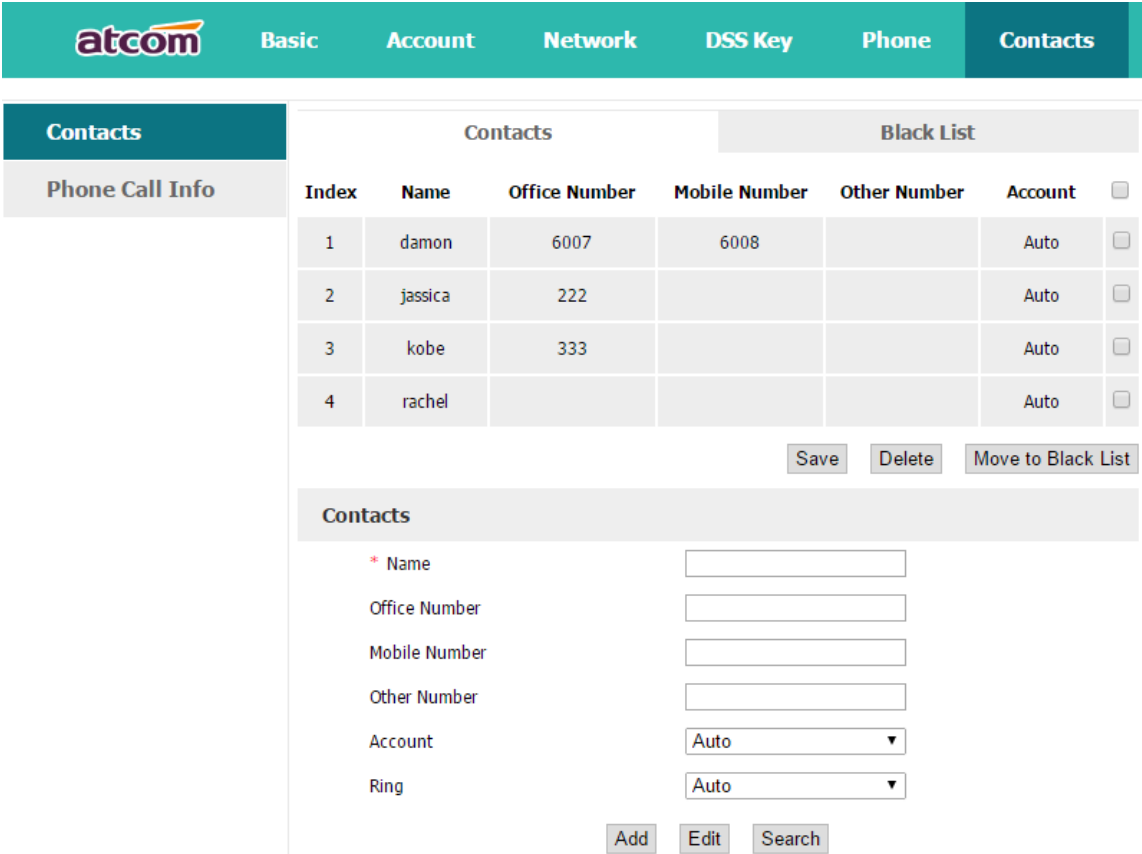

Contacts							Black List
Index	Name	Office Number	Mobile Number	Other Number	Account		
1	damon	6007	6008		Auto	<input type="checkbox"/>	
2	jassica	222			Auto	<input type="checkbox"/>	
3	kobe	333			Auto	<input type="checkbox"/>	
4	rachel				Auto	<input type="checkbox"/>	

---

**Contacts**

\* Name

Office Number

Mobile Number

Other Number

Account

Ring

All operations on Directory via Web will be not active until click "Save". When too much item existed in the Directory, it will be an easy way to search by keyword about name, Office Number, Mobile Number or other Number. The exactly matched item will be listed, otherwise you will be prompted "Not find the specified contact".

## Local phonebook

Name and phone number are permitted to be saved into the local phonebook, and up to 400 items. It's able to add new contact, edit or delete exist contact or dial, also move the item to blacklist.

### *Make calls from directory*

Path to set on the phone:  → **Directory** → **Local Contacts** → **Select the record** → **Dial**.

If only one phone number saved with the selected contact person, the phone number will be dialed while calling the contact person.

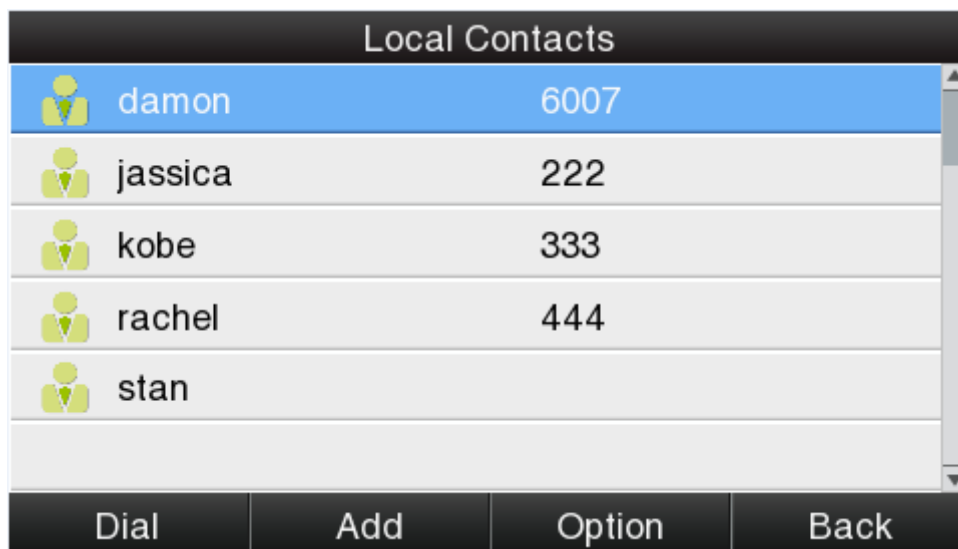

If multiple phone numbers saved with the selected contact person, user must select one of the phone numbers for dialing while calling the contact person.





*Add new contact*

Path to add new contact on the phone: Press  → **Directory** → **Local Contacts** → **Add**.

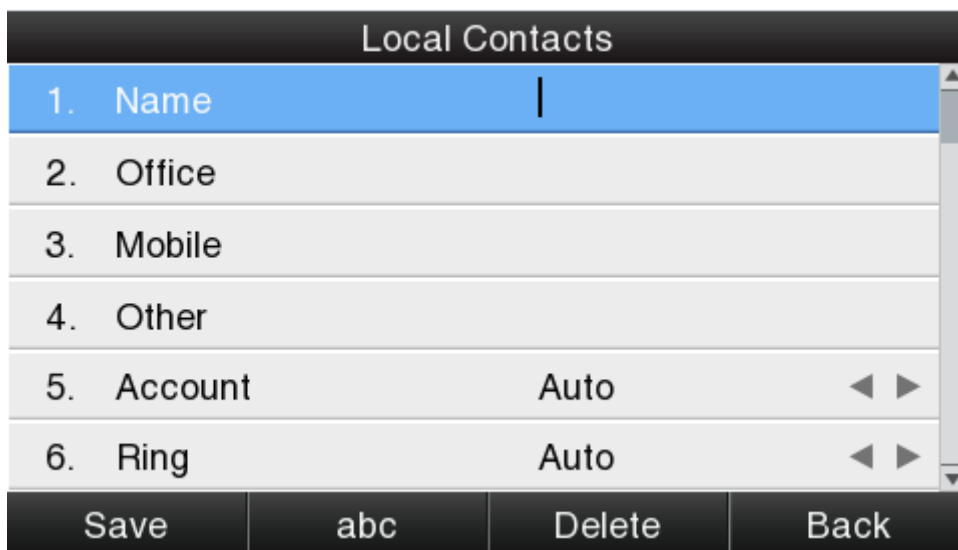

Item	Operation	Description
<b>Name</b>	Input by number keys, "*" or "#" key, change the input-method via pressing the soft key "abc"	It's used to identify different phone numbers. Any reduplicated names are not permitted in the directory.
<b>Office</b>	Input by number keys, "*" or "#" key, change the input-	You can save three numbers at most. While calling a contact person in directory, the phone will redirect to the page that to select one
<b>Mobile</b>		
<b>Other</b>		

	the soft key "abc"	number to dial when multiple numbers are saved for one contact record
<b>Account</b>	Press the key  ,  or the soft key "Switch" to modify the account ID.	It's used to bundle each item with the corresponding account, and the optional value is "Auto" or "Account 1" to "Account 6". "Auto" means the 1 <sup>st</sup> available account will be selected.
<b>Ring</b>	Press the key  ,  or the soft key "Switch" to modify the account ID.	It's used to bundle each item with the corresponding ringtone, and the optional value is "Auto" or "Ringtone 1" to "Ringtone 10". "Auto" means the default ringtone will be played if new incoming call happened, otherwise the selected ringtone will be played.
<b>Photo</b>	Only for preview. It's available for modification via Web only.	To identify a contact item by a specified image.

Add new contact via web: **Contacts**→**Contacts**→**Input messages**→**Add**→**Save**.

*Edit the contact*

User must re-edit the contact item while updating one item of local phonebook.

Path to edit the contact on the phone: **Press** →**Directory**→**Local Contacts**→**Select the item to edit**→**Option**→**Edit**→**OK**.

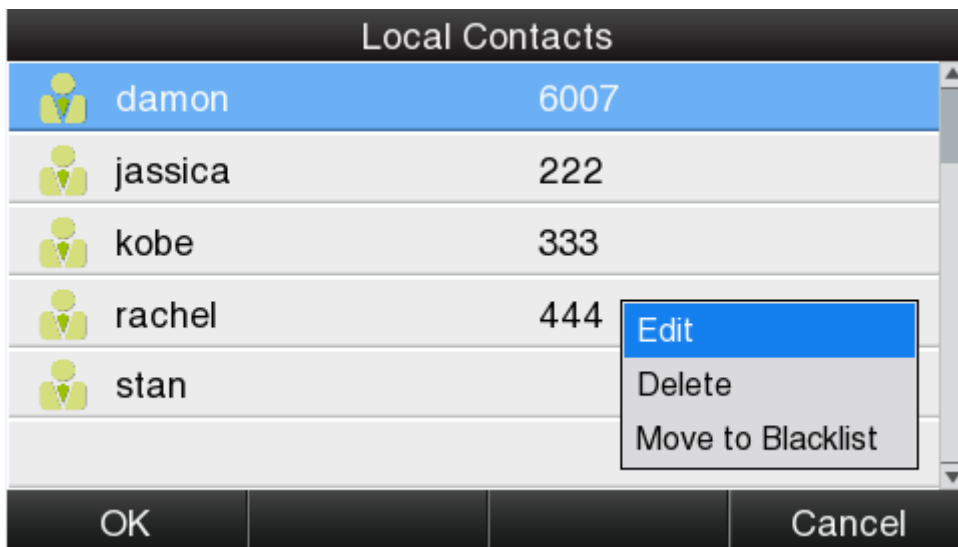

Edit the contact item via Web: **Contacts**→**Contacts**→**click on the item to edit**→**modify messages**→**Click "Edit"**→**Click "Save"**.

### *Delete the contact*

Path to delete the contact on the phone: Press  →**Directory**→**Local Contacts**→**Select the item to delete**→**Option**→**Delete**→**OK**→**OK**.

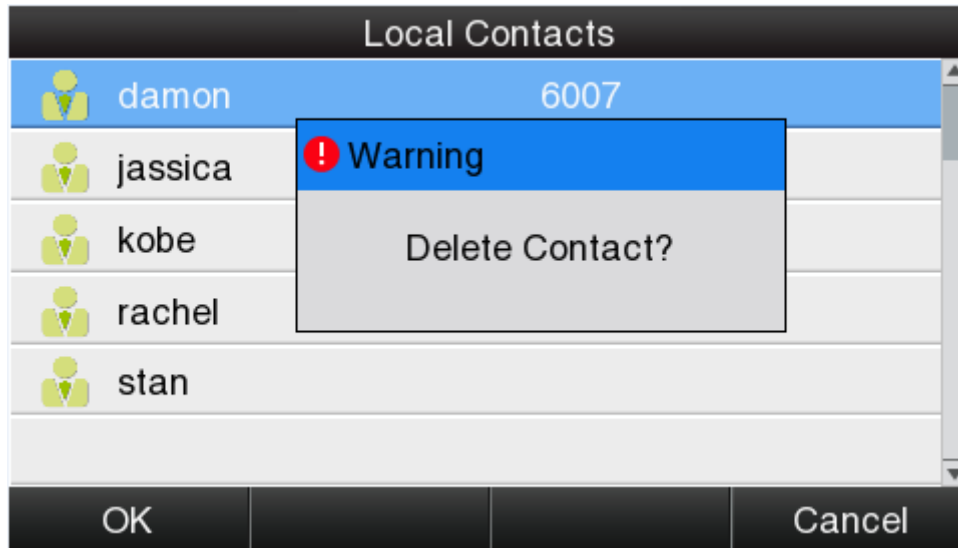

Press the soft key "**Cancel**" at the Warning UI to stop deleting.

Delete the contact item via web: **Contacts**→**Contacts**→**Select the item to delete**→**Click on "Delete"** →**Click on "Save"**.

### *Move to blacklist*

Path to move to blacklist on the phone: Press  →**Directory**→**Local Contacts**→**Select the item to move**→**Option** →**Move to Blacklist** →**OK**→**OK**.

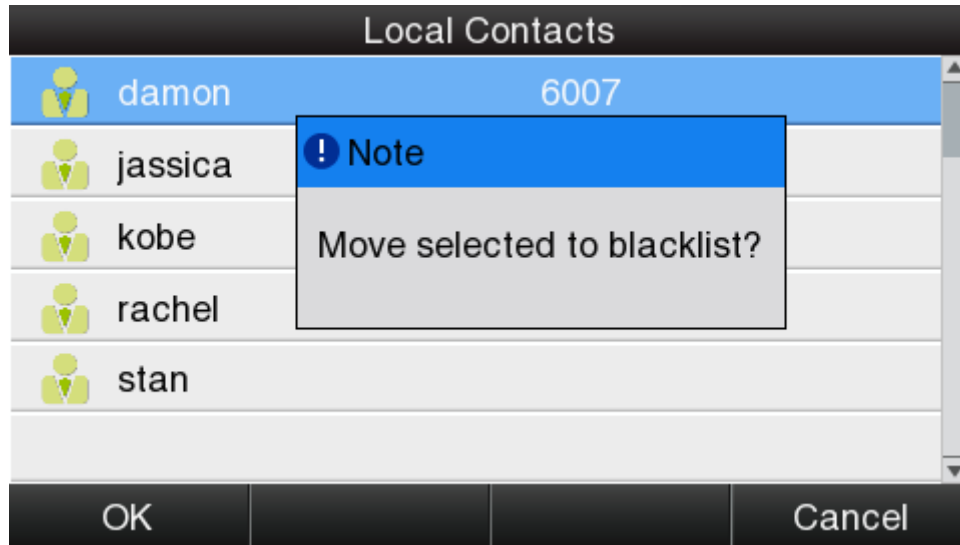

Press the soft key **“Cancel”** at the Warning UI to stop this operation.  
 Move the contact item to blacklist via web : **Contacts**→**Contacts**→**Select the item to move to blacklist**→**Click on “Move to black List”**→**Click on “Save”**。

## Blacklist



The purpose of blacklist’s feature is to block the phone number inside blacklist to call the host phone number, but it’s available for the hosted phone number to call any phone number in the black list.

The most operation of blacklist is the same as local phonebook except for the feature “Move to Contacts”, it means moving an item of blacklist to local phonebook to resume the phone number to dial the host phone number normally.

### 3.4.4、History

It includes the dialed, answered, missed and transferred items, maximum 400 items.

User is able to review or delete any item of the history on the phone. And enter “History” in below ways:

1. Press the key 
2. Press the key  , then select “History”
3. Press the soft key “History” while phone is under standby status







When any operations above is done, details info of all recent history will be listed on LCD display, include the type of each item, the name of contact person, date and time.

Also, user is able to check the detail info of call history via Web, but only review operation is allowed while accessing via web.

atcom Basic Account Network DSS Key Phone <b>Contacts</b>				
Contacts	Dialed List	Missed List	Received List	Forwarded List
Phone Call Info	Index	Datetime	Local Identity	Name Tel Number
	1	2014/11/17 16:22	5022@172.16.0.55:5060	damon 6750@172.16.0.55
	2	2014/11/17 16:21	5022@172.16.0.55:5060	700 700@172.16.0.55

## Make calls from history

Path to make calls from history on the phone: **Enter history UI**→**Select the item to dial**→**Dial**.

Call List		1/5
	6048	Fri. Nov. 14 11:55am
	6028	Fri. Nov. 14 11:54am
	6030	Fri. Nov. 14 11:54am
	damon	Fri. Nov. 14 11:53am
	700	Fri. Nov. 14 11:53am
	damon	Fri. Nov. 14 11:53am
Dial	Delete	Option Back

## Delete one item from history

Path to delete one item from history on the phone: **Enter history UI**→**Select the item to delete**→**Delete**.

## Check the details of history

Path to check the details of history on the phone: **Enter history UI**→**Select the item to check**→**Option**→**Detail**→**Press**  or "OK".

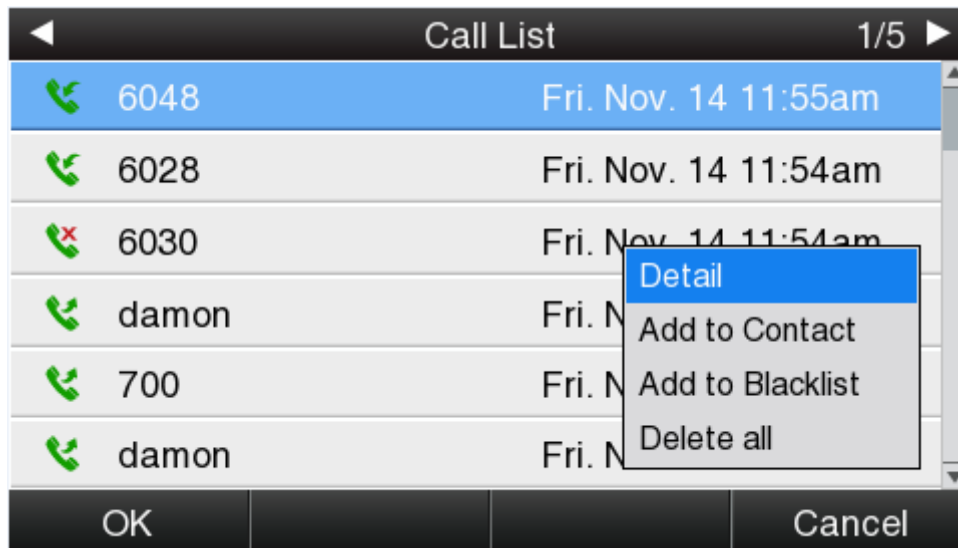

## Add to Contact

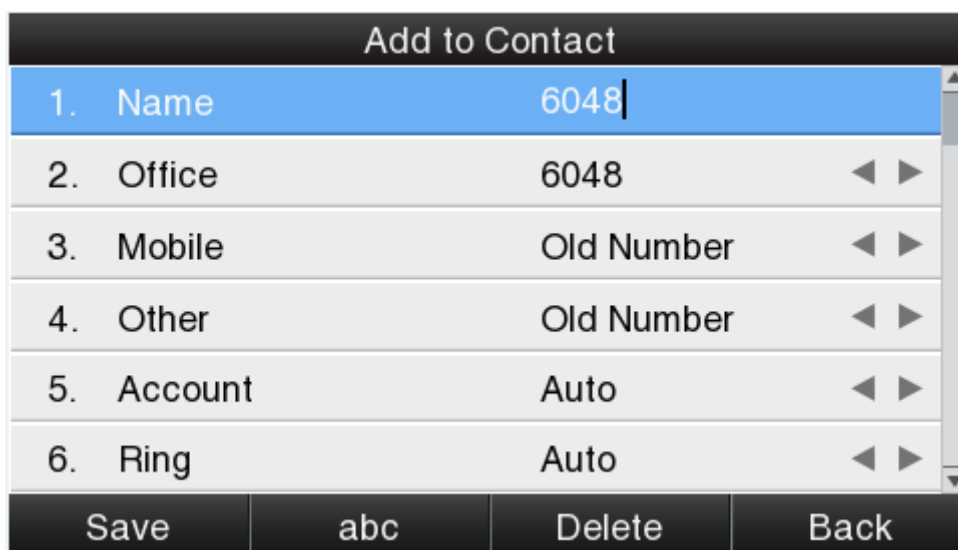

1. **Enter "Call History"**→**Select the target item**→**Option**→**add to Contact**→**Press the key**  or soft key "Confirm".

At this moment an "edit" page will be popped up.



The item of "Office", "Mobile" and "Other" are able to be switched over between "Old Number" and current number. If the being operated item had been saved already in the directory, "Old Number" will be the previous value, otherwise "Old Number" will be null. The UI page of "Add to Blacklist" is the same as above.

2. **Modify the contact name, phone number and ringtone.**

3. **Press the key  or soft key "Saved" to save the modification, press the key  or soft key "Cancel" to Cancel the modification.**

## Add to Blacklist

For more info about this operation, please refer to [Add to Contact](#).

## Delete all History's records

Path to delete all history's records on the phone: **Enter History**

**UI**→**Option**→**Delete all**→**Press  or "OK"**.

## 3.4.5、Message

User will benefit from the feature of voicemail when they're not available to answer an incoming call or missed some incoming calls. However this feature must be supported by Server. Voicemail must be set up before using it.

Set the voicemail via Web: **Account**→**Basic**→**Select an account to configure**→**Voice Mail**.



Sometimes the voicemail push can't be reached in time, because the configuration problem with Server, you must configure some related parameter via Web to make the phone automatically send its request to Server for getting voicemail info.

Set "Subscribe for MWI" via web: **Account**→**Advanced**→**Subscribe for MWI**.

Set "MWI Subscription Period(secs)" via web: **Account**→**Advanced**→**MWI Subscription Period(secs)**.

## Set Voice Mail

There is 3 different methods to set up the voicemail,

1. Press the key  after factory set
2. Press the key  for a while
3. Press the key  → Select "Message" → Setup Voicemail



## Check the voicemail

User is able to check voicemail in below ways:

1. Setup voicemail number → Press the key 
2. Press the key  → Select "Message" → "New Voicemail"

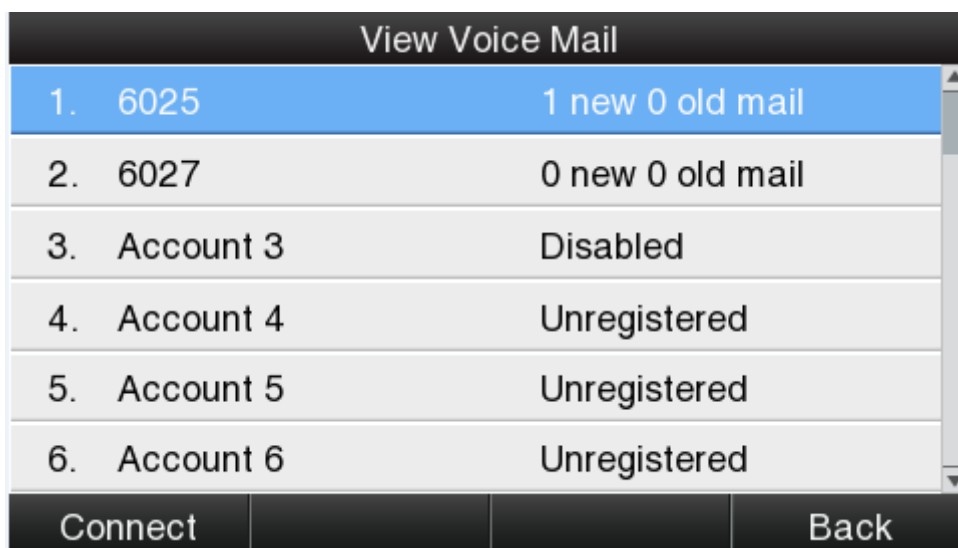



Select the account with "N new N old mail", and press the soft key "Connect", the corresponding voicemail will be connected.

Select the account with "Unregistered", and press the soft key "Connect", the setting page of Voicemail will be popped up.

### 3.4.6、Settings

Basic settings and Advanced settings will be introduces in this part,

Basic settings:

- [Language](#)
- [Time & Date](#)
- [Time & Date Format](#)
- [Ring tones](#)
- [Headset Memory Mode](#)

Advanced settings:

- [Accounts](#)
- [Set Password](#)
- [Network](#)
- [Reset to factory](#)

#### Basic Settings

##### *Language*

Rainbow4(s) supports multiple language, to modify the language, please press the key  → **Setting** → **Basic setting** → **Language** → **Select the target language and press the soft key "Save"**.



Set language via web: There is a drop-down box at the top left corner of webpage, choice one kind of language and click, the language will take effect immediately.

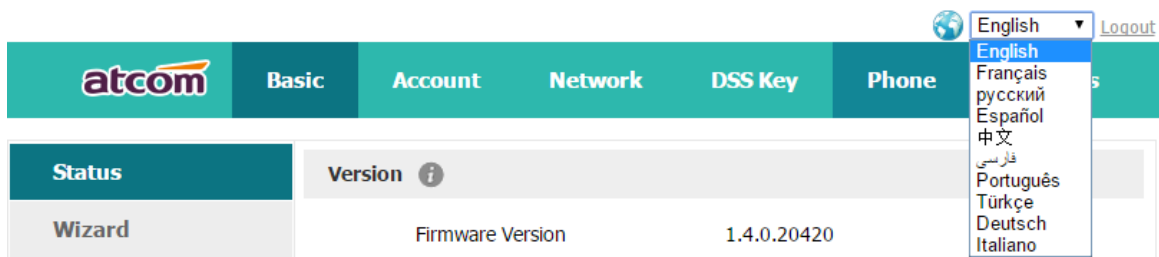

## *Time & Date*

Time & Date will be displayed at the standby page of Rainbow4(s), and these info will be related with all process of IP phone. "Time & Date" can be gained by NTP Server automatically or set manually.



## **NTP Setting**

Path to set on the phone: Press  → **Settings** → **Basic Settings** → **Time & Date** → **NTP Settings**.

NTP Settings	
1. Time Zone	+8China(Beijing) ◀ ▶
2. NTP Server	pool.ntp.org
3. Secondary NTP Server	time.windows.com
4. Daylight Saving	Disabled ◀ ▶
<div style="display: flex; justify-content: space-around;"> <span>Save</span> <span>Switch</span> <span>Back</span> </div>	

Item	Operation	Description
<b>Time Zone</b>	Press the key ◀, ▶ or □ soft key "Switch" to modify it.	Select the correct Time Zone for the IP phone.
<b>NTP Server</b>	Key in the IP address of domain name by the number keys, "*" , "#"	Specify the NTP Server
<b>Secondary NTP Server</b>	Key in the IP address of domain name by the number keys, "*" , "#"	Specify the standby NTP Server
<b>Daylight-Saving Time</b>	Press the key ◀, ▶ or □ soft key "Switch" to modify it.	Optional: "Off", "Auto" or "Manual". And "Manual" mean user must set this via web.

Set NTP via Web: **Phone**→**Preference**.

Time Zone	+8 China(Beijing) ▼	
Primary NTP Server	pool.ntp.org	
Secondary NTP Server	time.windows.com	
Update Interval(secs)	1000	
daylight	Disable ▼	
Fixed Type	<input checked="" type="radio"/> By Date <input type="radio"/> By Week	
Start Month	January ▼	
Start Date	1	
Start Hour of Day	0	
Start Day of Week	Sunday ▼	
Start Week of Month	First In Month ▼	
Stop Month	January ▼	
Stop Date	1	
Stop Hour of Day	0	
Stop Day of Week	Sunday ▼	
Stop Week of Month	First In Month ▼	
Offset(minutes)	0	

Item	Operation	Description
<b>Time Zone</b>	Click drop-down box to select	Set a time zone matches condition
<b>Primary NTP Server</b>	Manual input	The primary NTP server that provide time and date
<b>Secondary NTP Server</b>	Manual input	The secondary NTP server that provide time and date
<b>Update Interval(secs)</b>	Manual input	The interval that the phone gains time and date from NTP server
<b>Daylight</b>	Click drop-down box to select	A switch to control the status that whether to enable the daylight or not
<b>Fixed Type</b>	Radio content	Daylight fixed type, only the specified items are configurable
<b>Start Month</b>	Click drop-down box to select	The month that the daylight rule begins taking effect
<b>Start Date</b>	Manual input	The day that the daylight rule begins taking effect
<b>Start Hour of</b>	Manual input	The hour of day that the daylight

<b>Day</b>		rule begins taking effect
<b>Start Day of Week</b>	Click drop-down box to select	The day of week that the daylight rule begins taking effect
<b>Start Week of Month</b>	Click drop-down box to select	The week of month that the daylight rule begins taking effect
<b>Stop Month</b>	Click drop-down box to select	The month that the daylight rule stops taking effect
<b>Stop Date</b>	Manual input	The day that the daylight rule stops taking effect
<b>Stop Hour of Day</b>	Manual input	The hour of day that the daylight rule stops taking effect
<b>Stop Day of Week</b>	Click drop-down box to select	The day of week that the daylight rule stops taking effect
<b>Stop Week of Month</b>	Click drop-down box to select	The week of month that the daylight rule stops taking effect
<b>Offset(minutes)</b>	Manual input	The offset time that daylight rule takes effect

## Manual Settings

Path to set on the phone: Press  → **Settings** → **Basic Settings** → **Time & Date** → **Manual Settings**.

Manual Settings	
1. Year	2014
2. Month	11
3. Day	15
4. Hour	11
5. Minute	23
6. Second	53
Save	123
Delete	Back

Item	Operation	Description
<b>Year</b>	Key in "Year" with the number key, "*" and "#"	Date info
<b>Month</b>	Key in "Month" with the number key, "*" and "#"	
<b>Day</b>	Key in "Day" with the number key, "*" and "#"	

<b>Hour</b>	Key in " <b>Hour</b> " with the number key, "*"and "#"	Time info
<b>Minute</b>	Key in " <b>Minute</b> " with the number key, "*"and "#"	
<b>Second</b>	Key in " <b>Second</b> " with the number key, "*"and "#"	

Set the Time & Date manually via web: **Phone**→**Preference**.

Manual Time	Disable	
Date	<input type="text"/>	Generated Date
Time	<input type="text"/>	Generated Time

Item	Operation	Description
<b>Manual Time</b>	Click the drop-down box to select	A switch to control the status whether to enable the manual time or not
<b>Date</b>	Manual input, click "Generated Date" to gains date from the computer	Set date manually
<b>Time</b>	Manual input, click "Generated Time" to gains time from the computer	Set time manually

### *Time & Date Format*

Path to set on the phone: Press → **Settings**→**Basic Settings**→**Time & Date Format**.

Time & Date Format	
1. Clock	12 Hour
2. Date	WWW MMM DD
Save	Switch
Back	



Item	Optional	Example of result
Clock	12 hour	03:30pm
	24 hour	15:30
Date	WWW MMM DD	Tuesday Oct. 16
	DD-MMM-YY	16-Oct.-14
	YYYY-MM-DD	2014-10-16
	DD/MM/YYYY	16/10/2014
	MM/DD/YY	10/16/14
	DD MMM YYYY	16,Oct.,2014
	WWW DD MMM	Tuesday,16,Oct.

Set the Time & Date Format via Web: **Phone**→**Preference**

### Ring tones

10 different ring tones have been provided by Rainbow4(s) for selection. Path to set on the phone: **Press the key**  → **Settings**→**Basic Settings**→**Ring tones**.



For the selected ringtone, there is a dot inside the circle. Press the key  ,  to select other ringtone for playing.

Set ring tones via Web: **Account**→**Basic**→**Ring tones**.

### Headset Memory Mode

Headset memory mode can be used to control the default device to make or answer calls. This function is disabled by default, which means the phone will communicate with others by hand-free when pre-dial or making calls from history

or directory, and so is the situation that pressing "Answer" soft key to accept an incoming call. Once this function is enabled, the phone will make or answer calls by headset. Long press  can change the status of the "Headset Memory Mode".

This function can be configured on the phone only:

Press  → **Settings** → **Basic Settings** → **Headset Memory Mode**.

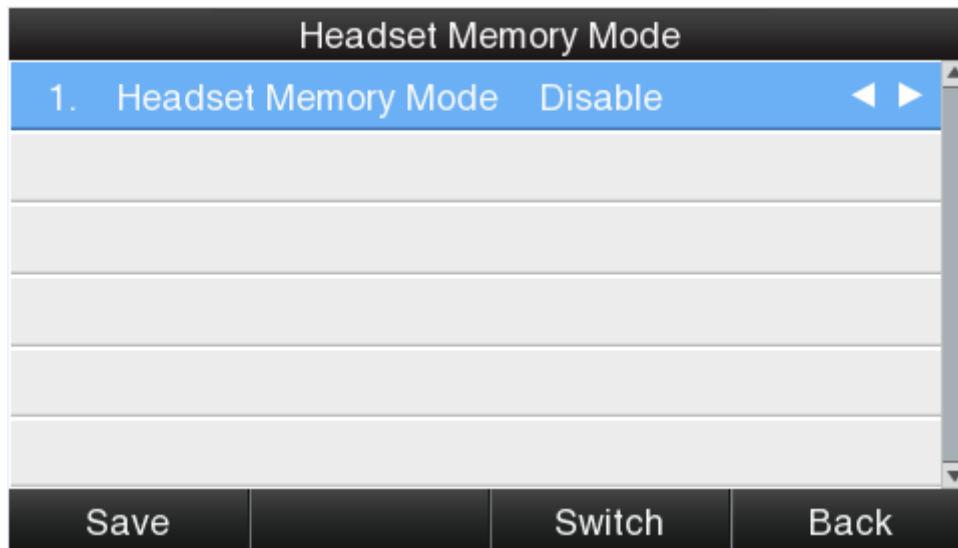

## Advanced Settings

Password will be requested while accessing the page of "Advanced Settings". This password is the same as the user's ("admin") to access.

### *Accounts*

Up to 6 accounts supported by Rainbow4(s), path to set the account info on phone: Press  → **Settings** → **Advanced Settings** → **Input password** → **Accounts**.



Accounts		
1.	6025	Registered
2.	6027	Registered
3.	6032	Register Failed
4.	6033	Disabled
5.	(Empty)	
6.	(Empty)	
Enter		Back

Status	Description
<b>Empty</b>	The account has not been configured yet
<b>Registered</b>	The account has been registered already
<b>Register Failed</b>	The account is register failed
<b>Disabled</b>	The account is disabled

Select the account and press the soft key **“Enter”** to access the page of account setting.

Account 1		
1.	Activation	Enable
2.	Label	
3.	Display Name	
4.	Register Name	
5.	User Name	6025
6.	Password	*****
Save		Switch
		Back

Item	Description
<b>Activation</b>	The status of account, the default is “Enable”, if set this as “Disable”, the account will be forbidden.
<b>Lable</b>	It will show on the phone, can skip this item
<b>Display Name</b>	Parameter that in the SIP, if the SIP Server is supportable, this name will show on the phone of callee
<b>Register Name</b>	The register ID, supplied by SIP Server, can skip this item

<b>User Name</b>	Account ID
<b>Password</b>	Password for account
<b>SIP Server</b>	The address that accounts needed to register from
<b>Outbound Status</b>	The status of Outbound Server, "off" by default
<b>Outbound Proxy</b>	IP address of Outbound Agency
<b>Stun Status</b>	The status of Stun Server, "off" by default
<b>Stun Server</b>	IP address of Stun Server

Configure account via web: **Account**→**Basic**

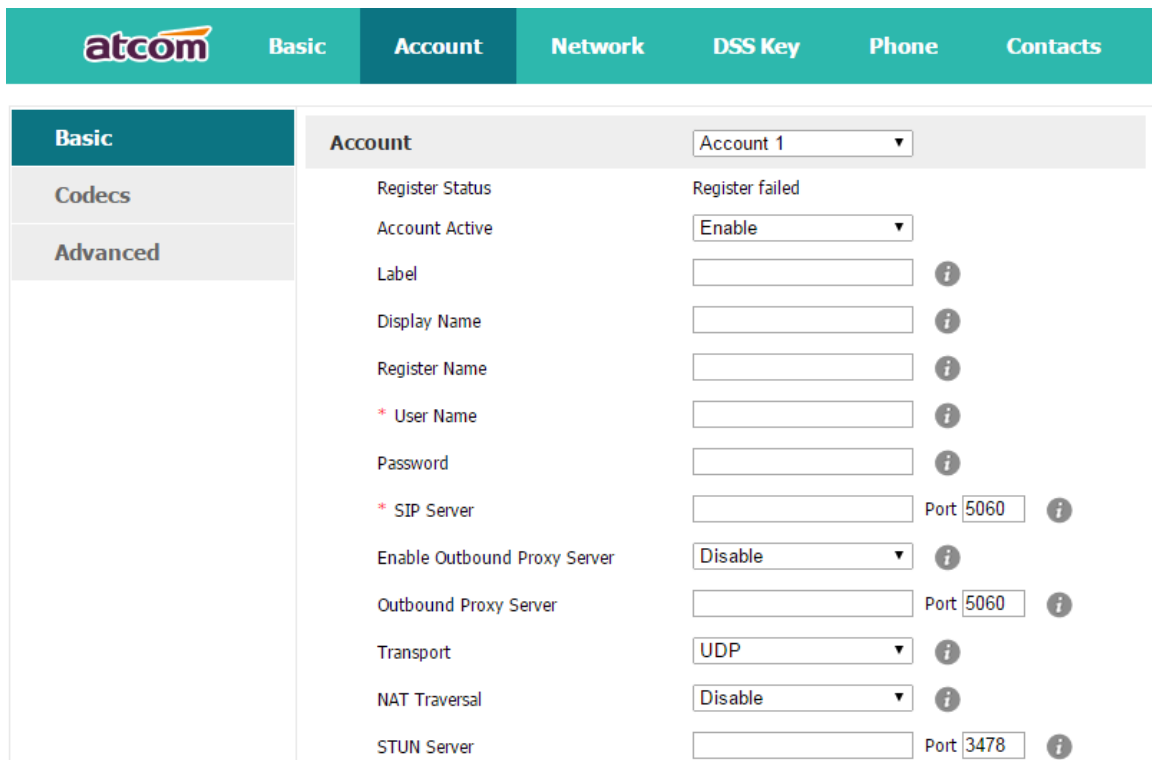

### *Set Password*

The password for Advanced Settings also is used for Web access as the role

"admin". Path to set password on phone: Press  → **Settings**→**Advanced Settings**→**Input password**→**Set Password**.

**Set Password**

1. Current PWD	
2. New PWD	
3. Confirm PWD	

Save
abc
Delete
Back

Item	Description
<b>Current PWD</b>	The current password for web access as the role of "admin", it's "admin" by default.
<b>New PWD</b>	To set the new password, blank is acceptable.
<b>Confirm PWD</b>	Input the new password again, to confirm the new password.

Set password via Web: **Phone**→**Security**.

Basic
Account
Network
DSS Key
Phone
Contacts

Preference	<b>Password Modify</b>
Features	User Type <span style="float: right;">?</span>
Upgrade	Current Password
Auto Provision	New Password
Configuration	Confirm Password
Dial Plan	<input type="button" value="Confirm"/> <input type="button" value="Cancel"/>
<b>Security</b>	
Debug	

## Network

Path to set network parameters on phone: Press  → **Settings** → **Advanced Settings** → **Input the password** → **Network**.

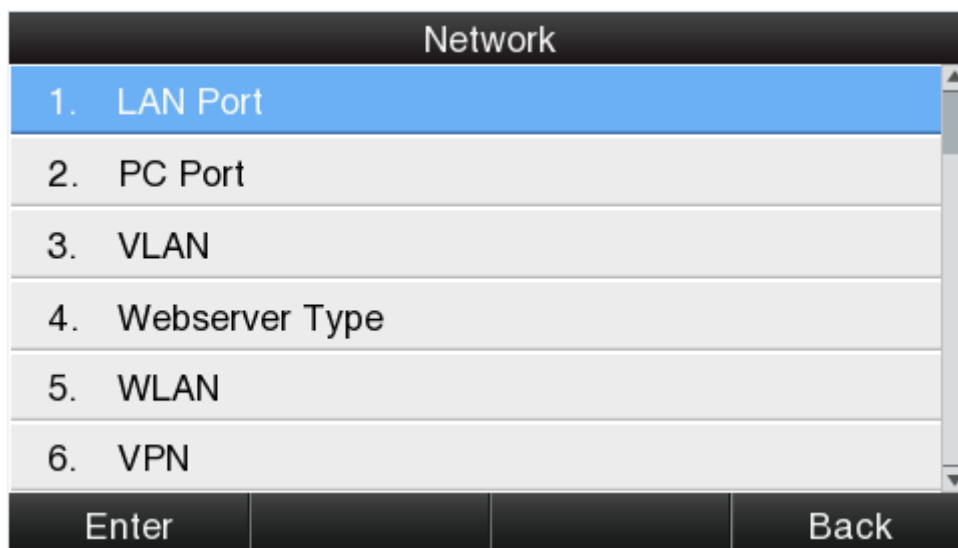

## LAN Port

Connect the phone with local network via LAN port, to gain IP address in 3 ways: DHCP, Static, PPPoE. Set the LAN port via Web: **Network** → **Basic**.

### DHCP

The phone gains IP address via DHCP by default.

### STATIC IP

If the phone gains IP address via Static IP, user must input the IP address info manually.

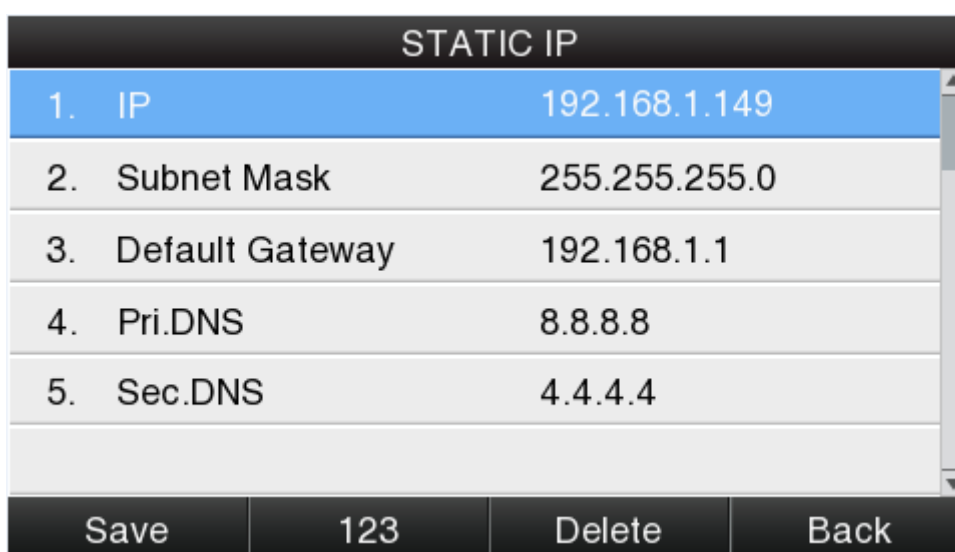

### PPPoE





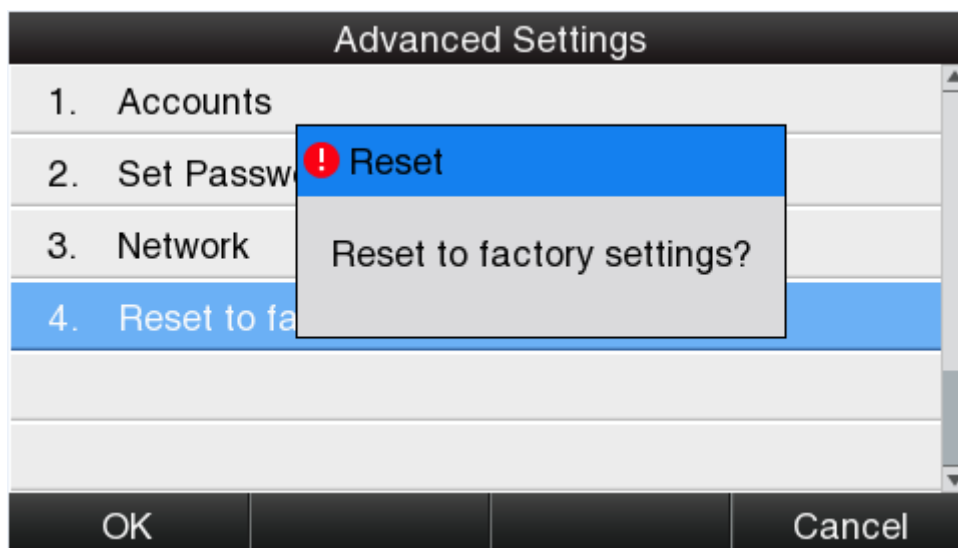



Reset to factory via Web: **Phone**→**Upgrade**→**Reset to Factory**.

### 3.4.7、Display

For more convenient, users are able to adjust the contrast grade and backlight of the main LCD display and the BLF LCD display.



#### Slave Contrast

There are 9 different contrast grades for options, press the soft key "**Switch**" or the key 、 for modification, 6 is the default value.



## Backlight

Backlight is the brightness of LCD, also it has been defined as 9 different grades. The number "9" means the lightest.

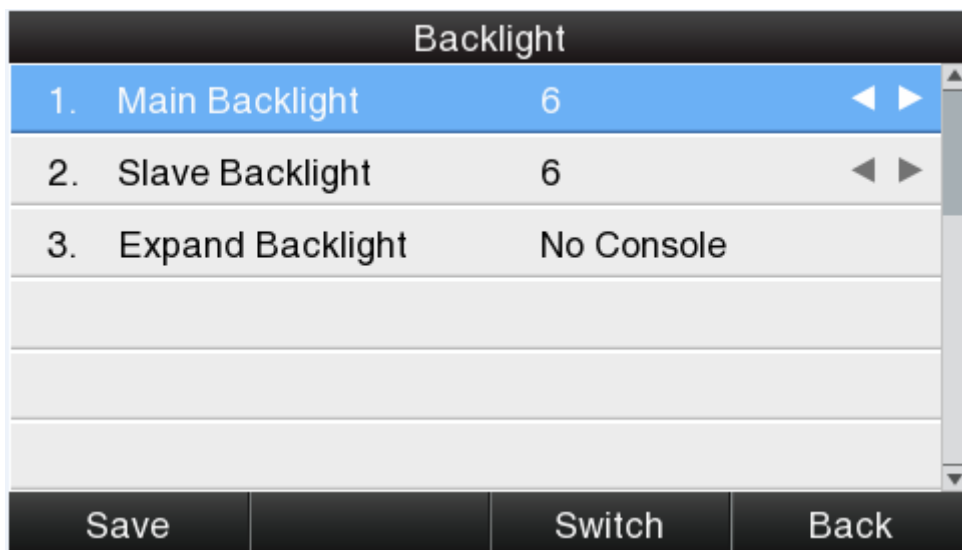

To adjust the brightness of LCD expansion module, it must be connected with the hosted phone. Otherwise the host phone will indicated "No expansion module" .

### 3.4.8、Application







## 4、Advanced Feature

### 4.1、Codecs

Rainbow4(s) support multiple codecs, users can select the codes via Web.

The screenshot shows the 'Account' configuration page for 'Account 1'. The 'Audio codecs' section is active, displaying two columns: 'Disabled Codecs' and 'Enabled Codecs'. The 'Disabled Codecs' list includes G723\_53, L16, G726-16, G726-24, G726-40, and iLBC\_15\_2. The 'Enabled Codecs' list includes PCMU, PCMA, G729, G722, G723\_63, iLBC\_13\_3, and G726-32. Navigation arrows are present between the lists and on the right side of the 'Enabled Codecs' list. 'Confirm' and 'Cancel' buttons are at the bottom.

Disabled Codecs	Enabled Codecs
G723_53	PCMU
L16	PCMA
G726-16	G729
G726-24	G722
G726-40	G723_63
iLBC_15_2	iLBC_13_3
	G726-32

 means to enable the item of “Disabled Codes”,  means to disable the item of “Enabled Codes”; click the button  or  to sort all enabled codes, the top item has the highest priority.  
Note: Multiple different items of G723, iLBC should not activated simultaneously.

## 4.2、 Capture and Upgrading

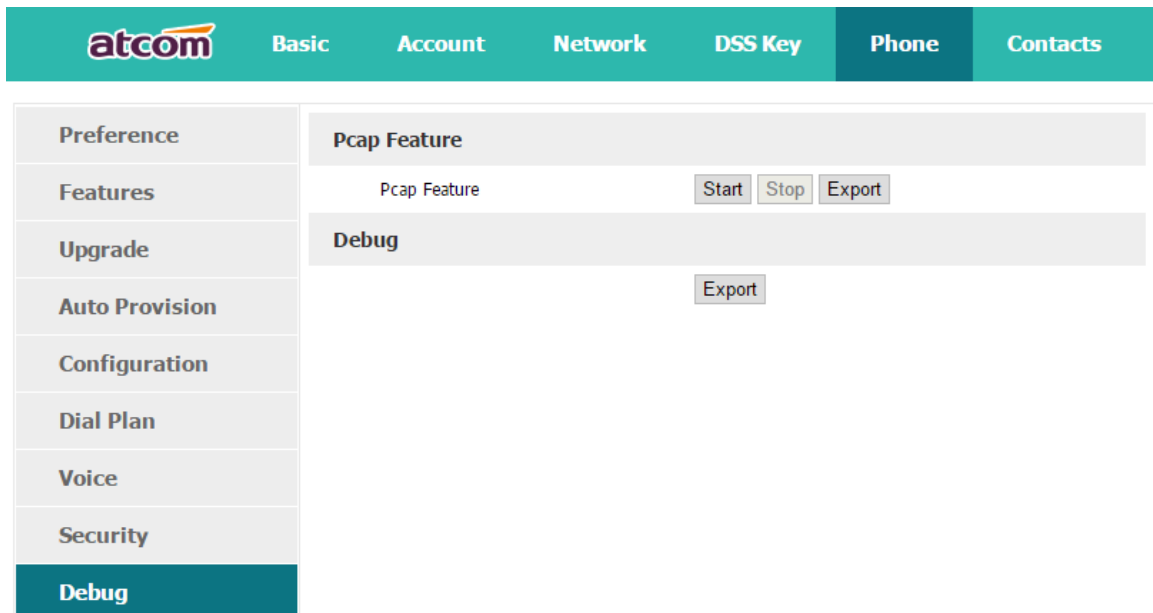

The screenshot shows the atcom web interface. The top navigation bar includes the atcom logo and tabs for Basic, Account, Network, DSS Key, Phone, and Contacts. The left sidebar contains a menu with options: Preference, Features, Upgrade, Auto Provision, Configuration, Dial Plan, Voice, Security, and Debug (which is highlighted). The main content area is divided into two sections: 'Pcap Feature' and 'Debug'. The 'Pcap Feature' section has a 'Pcap Feature' label and three buttons: 'Start', 'Stop', and 'Export'. The 'Debug' section has an 'Export' button.



Click the button “ Start” to start the capture and click the button “Stop” to end the capture. Then click the button “export” to download the capture file.

atcom		Basic	Account	Network	DSS Key	Phone	Contacts
Preference	<b>Version</b>						
Features	Firmware Version						1.5.0.20916
	Hardware Version						
<b>Upgrade</b>	<b>Reset to Factory</b>						
Auto Provision	Reset to Factory						<input type="button" value="Reset to Factory"/>
Configuration	<b>Reboot</b>						
Dial Plan	Reboot						<input type="button" value="Reboot"/>
Voice	<b>Upgrade Firmware</b> <span style="font-size: small;">i</span>						
Security	Select Firmware						<input type="button" value="Choose file"/> No file chosen
Debug							<input type="button" value="Upgrade"/>

Before upgrading the firmware of phone, users are suggested to check the version of current firmware. Click the button "Choose file" to select the target local file and click "Upgrade" to process upgrading, this will cost a couple of minutes. And after reboot, the phone will be upgraded successfully.

### 4.3. Auto Upgrade

User is able to configure the phone to upgrade automatically.

atcom		Basic	Account	Network	DSS Key	Phone	Contacts
Preference	<b>Auto Provision</b>						
Features	Provisioning Server	<input type="text"/>					
Upgrade	User Name	<input type="text"/>					
<b>Auto Provision</b>	Password	<input type="password"/>					
Configuration	AES Key	<input type="text"/>					
Dial Plan	Check New Config	<input checked="" type="radio"/> On <input type="radio"/> Off					
Voice	Repeatedly	<input type="radio"/> On <input checked="" type="radio"/> Off					
Security	Interval(minutes)	<input type="text" value="1440"/>					
Debug	Weekly	<input type="radio"/> On <input checked="" type="radio"/> Off					
	Time	<input type="text" value="23"/> : <input type="text" value="00"/> -- <input type="text" value="23"/> : <input type="text" value="59"/>					
	Day of week	<input checked="" type="checkbox"/> Sunday <input checked="" type="checkbox"/> Monday <input type="checkbox"/> Tuesday <input type="checkbox"/> Wednesday <input type="checkbox"/> Thursday <input type="checkbox"/> Friday <input checked="" type="checkbox"/> Saturday					
	<input type="button" value="Confirm"/>		<input type="button" value="Cancel"/>				

Item	Description
<b>Provisioning Server</b>	The address to save control file for auto upgrading, it can filled by http、https、tftp server、ftp server, for example, tftp://192.168.1.111/upgrade_control_file.xml
<b>User Name</b>	The user name to access the file server
<b>Password</b>	The password to access the file server
<b>AES Key</b>	If the configuration file has been encrypted, the AES key will be used to decrypt for auto-upgrading
<b>Check New Config</b>	If set this parameter as "On", the phone will do some check for upgrading, and it will upgrade automatically once the conditions are met
<b>Repeatedly</b>	If set this parameter as "On", the phone will do some check for upgrading after "Interval(minutes)", and it will upgrade automatically once the conditions are met
<b>Interval(minutes)</b>	This parameter is configurable once the Repeatedly is "On"
<b>Weekly</b>	If set this parameter as "On", the phone will do the check for upgrading at a certain time in every week
<b>Time</b>	The time range that the phone do the check for upgrading every week, and it's configurable once the Repeatedly is "On"
<b>Day of week</b>	The day of week that the phone do the check for upgrading every week, and it's configurable once the Repeatedly is "On"

The sample of control file:

```

<?xml version="1.0"?>
<AUTOUPDATE Model="Rainbow4(s)">
  <Config URL="http://www.atcom.com.cn/temp/$MAC.tar.gz"/>
  <PhoneBook URL="tftp://192.168.1.190/phonebook.xml"/>
  <Firmware MD5="cadfadfaqedadfadfa"
    URL="http://www.atcom.com.cn/temp/Rainbow4(s)-V1.5.1.fw"/>
</AUTOUPDATE>

```

**\$MAC.tar.gz** refers to the specified files that named as the phones' MAC address, the phone will find the tar.gz file which named as its MAC address automatically once a phone uses this control file to upgrade the Config file at the specified location, for example, a Rainbow4(s)'s MAC address is EA:F5:GA:54:4D:DR, the corresponding control file should name as EAF5GA544DDR.tar.gz.

**MD5** is the property of a file, and it's always used for integrity checking, you can get it by using specified software. When upgrade the Firmware, the phone will compare the firmware's MD5 with the specified MD5, and it will refuse to upgrade if them are not the same.

#### 4.4. Export & Import configuration file

If user wants to set the same configuration on multiple phones, there is an easy way that export the configuration file from one phone and then import this file into other phones. This operation can be completed via Web only.

Note: This operation is available for the same models only.

**Import / Export Config**

Import File 

Choose file No file chosen

Import Export  Export User Data

##### 4.4.1. Export configuration file

There is two ways to export the configuration files,

- Don't check the "Export User Data" and click "Export" directly, it will export the template of the configuration file;
- Check the "Export User Data" and then click "Export", it will export a configuration file that carries with user's configured data.

To modify the exported configuration file, you should to decompress it until you get a file names as configuration.

Name	Date modified	Size
configuration	2014/10/10 11:14	
config.tar.gz	2014/10/10 11:14	9 KB

The content of configuration file listed as below,

Name	Date modified	Type	Size
Calllist	2014/10/10 11:14	File folder	
Contacts	2014/10/10 11:14	File folder	
DialRule	2014/10/10 11:14	File folder	
Features	2014/10/10 11:14	File folder	
Network	2014/10/10 11:14	File folder	
Phone	2014/10/10 11:14	File folder	
Setting	2014/10/10 11:14	File folder	
voip	2014/10/10 11:14	File folder	

#### 4.4.2、 Import configuration file

Click the button "Choose file" to select the target file for importing, and then click the button "Import". The phone will be rebooted a couple of minutes later, and import successfully.

Note: If some part of the configuration file has been modified manually, it must be re-compressed as the format of "tar.gz".

#### 4.5、 Export System log

When the phone doesn't working well, System log is the best assistant tools for troubleshooting, all operation details has been recorded. This operation is available via Web only.

### Export System Log

Log Location  Local  Server ?

Server Name

Log Level

Item	Description
<b>Log Location</b>	You can import the system log to local PC or remote Server.
<b>Server Name</b>	User must fill the address of server if you choose to export the system log to remote server.
<b>Log Level</b>	It defines the detail of system log as 5 different levels, Fatal, Error, Warning, Info, and Debug. The Debug level is the most detailed.

## 4.6、Dial plan

The customized Dial Plan are available on Rainbow 4(s), for example , the rule of replacement, Instant Calling, Area code, Restriction of Outbound.

Before customizing the dial plan, user must learn the basic grammar as below,

.	Represent a character or multiple ones, e.g., "6." can match "66","678","6plus" and so on
x	Represent one character, e.g., "6x" can match "61","62", " 6s" and so on
[]	Represent a character in one range, e.g., " 83[0-5]18618" can match "83018618","83488618" and so on
()	Represent the combination of characters, e.g., "([1-9])([2-7])3" can match "923","153","773" and so on
\$	Add a number after the character "\$" to define the location of the characters, e.g., use the prefix " 8([1-3])(.)" to replace "7\$2", the phone will call "7837" after dialing out "82837"

Note: Any operations (add, modify or delete) on the current dial plan will be not effective until click "Save".

### 4.6.1、Replace Rule

Dial plan "Replace Rule" means to replace a batch of complicated character string by some simple characters, to make a speed dial.

atcom																				
Basic	Account	Network	DSS Key	Phone																
<div style="display: flex; justify-content: space-between;"> <div style="width: 20%;"> <p>Preference</p> <p>Features</p> <p>Upgrade</p> <p>Auto Provision</p> <p>Configuration</p> <p><b>Dial Plan</b></p> </div> <div style="width: 80%;"> <table border="1"> <thead> <tr> <th>Replace Rule</th> <th>Dial-now</th> <th>Area Code</th> <th>Block Out</th> </tr> </thead> <tbody> <tr> <td>Index</td> <td>Number</td> <td>Replace</td> <td>Account <input type="checkbox"/></td> </tr> <tr> <td>* Number</td> <td><input type="text"/></td> <td>* Replace <input type="text"/></td> <td>Account <input type="text"/></td> </tr> <tr> <td colspan="4" style="text-align: center;"> <input type="button" value="Add"/> <input type="button" value="Edit"/> <input type="button" value="Delete"/> <input type="button" value="Save"/> </td> </tr> </tbody> </table> </div> </div>					Replace Rule	Dial-now	Area Code	Block Out	Index	Number	Replace	Account <input type="checkbox"/>	* Number	<input type="text"/>	* Replace <input type="text"/>	Account <input type="text"/>	<input type="button" value="Add"/> <input type="button" value="Edit"/> <input type="button" value="Delete"/> <input type="button" value="Save"/>			
Replace Rule	Dial-now	Area Code	Block Out																	
Index	Number	Replace	Account <input type="checkbox"/>																	
* Number	<input type="text"/>	* Replace <input type="text"/>	Account <input type="text"/>																	
<input type="button" value="Add"/> <input type="button" value="Edit"/> <input type="button" value="Delete"/> <input type="button" value="Save"/>																				

Item	Description	Sample
<b>Number</b>	The string works as replacer, not null	Set Number as "6", Set Replace as "6032", Set Account as "1, 3, 4". It means when dial 6, the phone will dial 6032 via the 1st available line in account 1,3,and 4 automatically
<b>Replace</b>	The string that to be replaced, not null	
<b>Account</b>	The account to apply this dial plan, blank or 1 to 6 is valid. Number 1 to 6 means account 1 to 6. If you want to apply this rule to account 1, 3 and 4, just type in <b>1,3,4</b> ; And if keep it as blank, it means applying this dial plan to all accounts	
<b>Add</b>	Multiply replace rules can be configured in one phone, after one replace dial plan configured, click this button to add a new one	
<b>Edit</b>	The existed replace dial plans are editable. The specified dial plan should be selected until it is covered with orange and the input fields "Number" and "Replace" shows the details correctly. After modifying, click button "Edit" to make it to be effect	
<b>Delete</b>	Delete one added or saved replace dial plan or multiple ones, click the frame after the specified replace dial plan before delete it, and then click button "Delete"	
<b>Save</b>	Any alteration won't take effect until the button "Save" is clicked.	



## 4.6.2、Dial-now

Dial plan “Dial-now” permits the corresponding phone to be dialed instantly without pressing the soft key “Dial”, once the input has been matched. It works like a hotline.

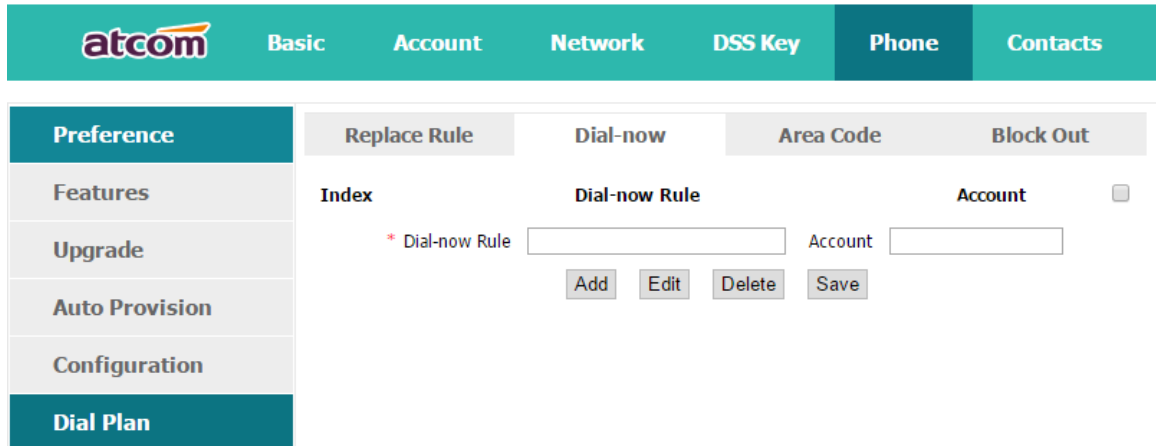

Item	Description	Sample
<b>Dial-now Rule</b>	The string to be dialed out automatically by the phone	Set “Dial-now Rule” as 6xxx,
<b>Account</b>	The account to apply this dial plan, blank or 1 to 6 is valid. Number 1 to 6 means account 1 to 6. If you want to apply this rule to account 1, 3 and 4, just type in <b>1,3,4</b> ; And if keep it as blank, it means applying this dial plan to all accounts	keep “Account” as null
<b>Add</b>	Multiply dial-now rules can be configured in one phone, after one dial-now dial plan configured, click this button to add a new one	It means the phone will use the 1st available account to call 6033 after “Dial-now Time-out” seconds when inputting four figures begin with 6
<b>Edit</b>	The existed dial-now dial plans are editable. The specified dial plan should be selected until it is covered with orange and the input fields “Number” and “Dial-now” shows the details correctly. After modifying, click button “Edit” to make it to be effect	Note: Dial-now rule is different with hotline. The Dial-now rule will take effect when input numbers matches the dial plan, and hotline takes effect in situation that the phone is in dialing state
<b>Delete</b>	Delete one added or saved dial-now dial plan or multiple ones, click the frame after the specified dial-now dial plan before delete it, and then click button “Delete”	
<b>Save</b>	Any alteration won’t take effect until	

the button "Save" is clicked.

Set "Dial-now Time-out" via web: **Phone**→**Features**→**General Information**→**Dial-now Time-out (secs)**.

### 4.6.3、Area Code

Dial plan "Area Code" has been defined to identify each different area. To call a phone number of other areas, user must add the area code to be in front of the phone number. For convenience, area code has been recommended to be configured while frequently dialing to that type of phone number.

Item	Description	Sample
<b>Code</b>	The area code dialed before the number	Set "Code" as "0086577", Set "Account" as "5", Set "Minimum length" as "5". It means when dialing 83018618 with the 5 <sup>th</sup> account, the phone will dial 0086577 before it. <b>Note: If the length of the number input in the dial UI is not between minimum length and the maximum length, area code will not take effect</b>
<b>Minimum length</b>	The minimum length of the number input to active the area code dial plan	
<b>Maximum length</b>	The maximum length of the number input to active the area code dial plan	
<b>Account</b>	The account to apply this dial plan, blank or 1 to 6 is valid. Number 1 to 6 means account 1 to 6. If you want to apply this rule to account 1, 3 and 4, just type in <b>1,3,4</b> ; And if keep it as blank, it means applying this dial plan to all accounts	
<b>Confirm</b>	Apply this dial plan	
<b>Cancel</b>	Recover all input fields to the state that saved at latest time	

#### 4.6.4、Block Out

Dial plan “Block out” is used to prohibit the phone number outgoing call from some accounts.

atcom				
Basic Account Network DSS Key Phone Contacts				
Preference	Replace Rule	Dial-now	Area Code	Block Out
Features	Block Out Number1	<input type="text"/>	Account	<input type="text"/>
Upgrade	Block Out Number2	<input type="text"/>	Account	<input type="text"/>
Auto Provision	Block Out Number3	<input type="text"/>	Account	<input type="text"/>
Configuration	Block Out Number4	<input type="text"/>	Account	<input type="text"/>
<b>Dial Plan</b>	Block Out Number5	<input type="text"/>	Account	<input type="text"/>
	Block Out Number6	<input type="text"/>	Account	<input type="text"/>
Voice	Block Out Number7	<input type="text"/>	Account	<input type="text"/>
	Block Out Number8	<input type="text"/>	Account	<input type="text"/>
Security	Block Out Number9	<input type="text"/>	Account	<input type="text"/>
	Block Out Number10	<input type="text"/>	Account	<input type="text"/>
		<input type="button" value="Confirm"/>	<input type="button" value="Cancel"/>	

Item	Description	Sample
<b>Block Out Number</b>	The number that prohibited	Set “Block Out Number 1” as “10086”
<b>Account</b>	The account to apply this dial plan, blank or 1 to 6 is valid. Number 1 to 6 means account 1 to 6. If you want to apply this rule to account 1、3 and 4, just type in <b>1,3,4</b> ; And if keep it as blank, it means applying this dial plan to all accounts	Set “Account” as “2,4,6” It means the phone will enter the “Call End” UI when dial “10086” with account 2, 4 or 6
<b>Confirm</b>	Apply this dial plan	
<b>Cancel</b>	Recover all input fields to the state that saved at latest time	

## 5、FAQ

## 5.1. How to reset to factory

There are 3 methods for factory reset:

### 1. Factory reset via phone:

- a) Press the key 
- b) Select "Settings", then press the soft key "Enter"
- c) Select "Advanced Settings", then press the soft key "Enter"
- d) Input the access password, then press the soft key "Enter"
- e) Select "Reset to factory", then press the soft key "Enter"
- f) Press the soft key "OK", then the phone will be reboot and resumed to factory default settings

### 2. Factory reset via Web:

- a) Key in the IP address of phone with a browser,
- b) Access the webpage of phone as the role of "admin", username/password is admin/admin.
- c) Select "Phone"
- d) Select "Upgrade"
- e) Click the button "Reset to Factory"
- f) Click the button "OK"

### 3. Factory reset during starting:

- a) Hold the key "\*" and "#" while power on for 5 seconds
- b) The phone will be reboot and resumed to factory default setting

## 5.2. Upgrade the firmware on safe mode

If the phone can't be started successfully, user is able to upgrade the firmware on post mode,

- a) Setup a TFTP Server and set the PC's IP address as "192.168.1.200"
- b) Copy the firmware file we supplied to the root menu of TFTP Server, modify the file's name as Rainbow4.tar.gz and decompress it, then modify the corresponding file's name as Rainbow4(s).kn, Rainbow4(s).fs, Rainbow4(s).fw, Rainbow4(s).lg
- c) Ensure the TFTP Server and phone are connected to the same network switch and both reachable
- d) Long Press the key "\*" and "1" to upgrade the kernel file, long Press the key "\*" and "2" to upgrade the firmware file, long Press the key "\*" and "3" to upgrade the App file, long Press the key "\*" and "4" to upgrade the logo file, and then plug in power until "upgrading..." displayed on LCD
- e) The phone will start downloading file from TFTP server
- f) After downloading completed, the phone will be automatically upgraded

- g) After upgrading completed, the phone will be started with the factory default settings

### **5.3、 How to make IP Peer to Peer call**

To make a IP peer to peer call, user should press "\*" to input "." that in the IP address. For example, to dial "192.168.1.100", just need input "192", "\*", "168", "\*", "1", "\*", "100".

## **6、 Trouble shooting**

### **6.1、 The phone is failed to register to SIP server**

1. First of all, check the IP address. If the LAN port is DHCP, please ensure the DHCP server has been enabled.
2. Check the network gateway
3. Check the DNS
4. Make sure the input account matched the one provided by Service Provider
5. Make sure SIP Server has been enabled already
6. Make sure the Port of SIP Server, it's 5060 by default

### **6.2、 The phone is failed to gain IP address**

1. Make sure the network cable has been plugged into the LAN port
2. Make sure the network cable or port of network switch are working fine,
3. Make sure the DHCP server has been enabled, and there are available IP address
4. Try to set the LAN port as Statics IP

### **6.3、 Only one party can hear from another on calling**

1. Try to make a IP peer to peer call, to make sure the mic and speaker are working fine
2. Enable STUN via Web

3. Set the address of STUN Server, for example `stun.sipgate.com`
4. Present this operation above and the phone will be reboot
5. Try to make a normal call again

## 7、 Abbreviation

DND: Do Not Disturb  
CFWD: Call Forward  
Bxfer: Blind Transfer  
Conf: Conference  
Num: Number  
SIP: Session Initiate Protocol  
RTP: Real-time Transport Protocol  
SDP: Session Description Protocol  
VPN: Virtual Private Network  
VLAN: Virtual Local Area Network  
QoS: Quality of Service  
Syslog: System log  
UDP: User Data Protocol  
TCP: Transmission Control Protocol  
TLS: Transport Layer Security Protocol  
BLF: Busy Lamp Field  
DNS: Domain Name System  
SRTP: Secure Real-time Transport Protocol  
NTP: Network Time Protocol  
VAD: Voice Activity Detection  
CNG: Comfort Noise Generator